

Gang Plate Dust Cover

For Use In FL-500P and FL-400/FL-600P Floor Boxes

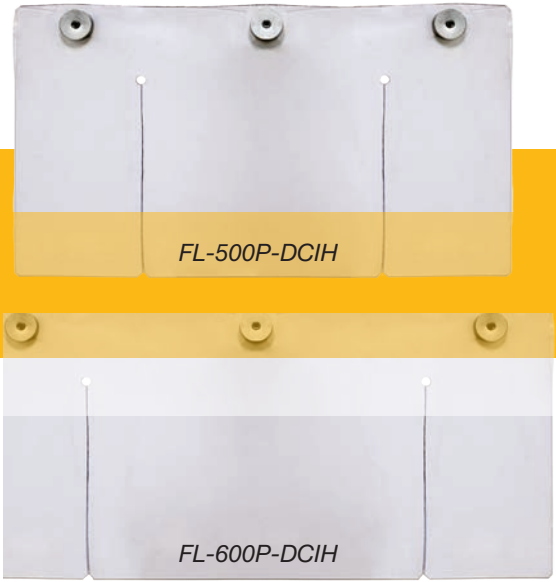

Metal Products Group



DESCRIPTION

FSR's dust covers for use in our FL-400, 500P, and 600P series floor boxes represent a proactive solution to address the need for enhanced protection of in-floor connectors. Each dust cover is constructed with strong neodymium magnets and heavyweight vinyl, ensuring they stay in place while safeguarding against debris and potential damage to connectors. These durable dust covers were designed with premium 40 Mil fire-retardant vinyl, which meets NFPA-701 and MVSS 302 requirements. The PVC vinyl material is crystal-clear, anti-static, and resistant to UV rays, tearing, and abrasion.

The necessity for such protection arises from the understanding that even minute amounts of debris entering connectors, such as HDMI or USB-C, pose significant risks of permanent damage to both the connector and the electronic devices to which they are connected. By implementing gang plate dust covers, FSR aims to mitigate the potential risks associated with debris ingress, protecting the functionality of the connectors.

FEATURES

- 40 Mil Clear View Vinyl
- Flame retardant material meeting NFPA-701 and MVSS 302
- Resistant to UV rays and anti-static
- Resistant to tearing and abrasion
- Protects in-floor connectors against dust and debris
- Constructed with the world's strongest magnet
- Easy to clean
- Save time and money replacing damaged connectors

ORDERING INSTRUCTIONS

Floor Box Gang Plate Dust Covers
For use with
FL-500P and FL-400/FL-600P Floor Boxes

Item#	Part#	Description
18667	FL-500P-DCIH	(2) Gang Plate Dust Covers for FL-500P
18668	FL-600P-DCIH	(2) Gang Plate Dust Covers for FL-400 and FL-600P

FSR Inc.

244 Bergen Boulevard, Woodland Park, NJ 07424
 Phone: 973.785.4347 · Fax: 973.785.4207
 Order Desk: 1-800-332-FSR1
 Web: fsrinc.com · E-mail: sales@fsrinc.com LIT1898A

PROTECT YOUR IN-FLOOR CONNECTORS FROM DUST & DIRT

Dust Cover
affixed in
FL-500P
floor box

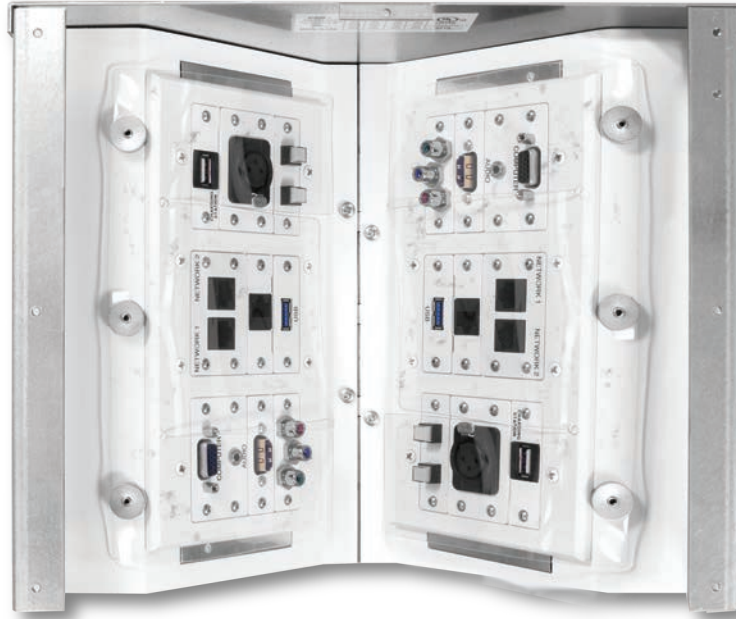

GANG PLATE DUST COVER DETAIL DRAWING

FL-500P-DCIH

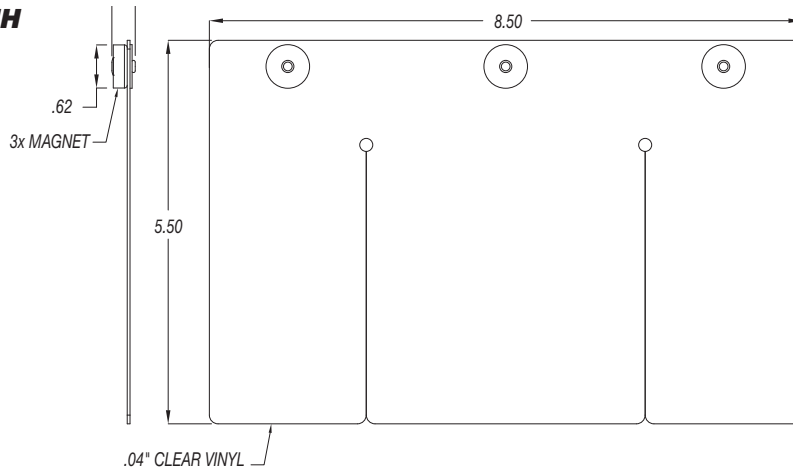

FL-600P-DCIH

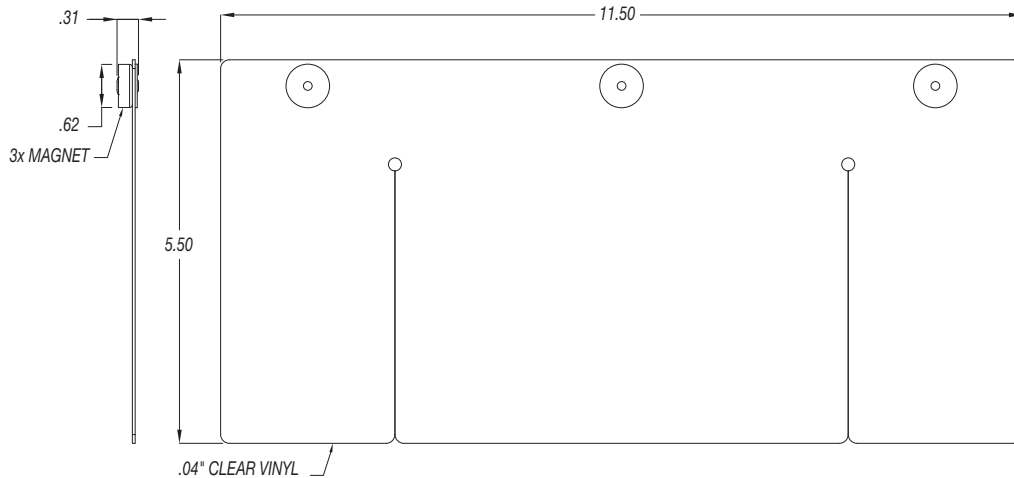

244 Bergen Boulevard, Woodland Park, NJ 07424
 Phone: 973.998.2300 · Fax: 973.785.4207
 Web: www.fsrinc.com · E-mail: sales@fsrinc.com