

4

3

2

1

C

C

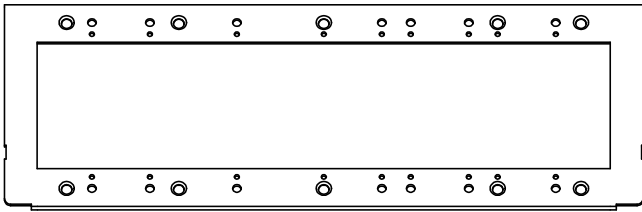

1 P/N: 54418 - GANG INSERT PLATE (1 SUPPLIED)
HARDWARE REQUIRED:
P/N: 11511 - #8-32 x 1/4" LONG PAN HEAD SCREW
(2 REQUIRED PER PLATE)

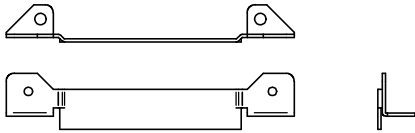

2 P/N: 55639 - GAP FILL / DIVIDER HOLDER (2 SUPPLIED)
HARDWARE REQUIRED:
P/N: 13330 - #8-32 x 1/4" LONG FLAT HEAD SCREW
(2 REQUIRED PER HOLDER)

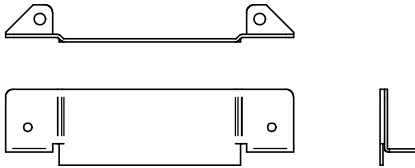

3 P/N: 54287 - CENTER DIVIDER HOLDER (1 SUPPLIED)
HARDWARE REQUIRED:
P/N: 13330 - #8-32 x 1/4" LONG FLAT HEAD SCREW
(2 REQUIRED PER HOLDER)

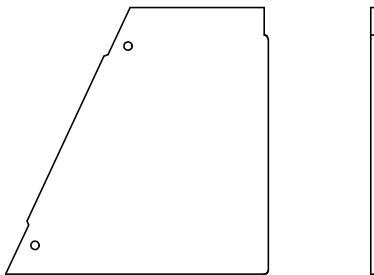

4 P/N: 54419 - INTERNAL DIVIDER (2 SUPPLIED)
HARDWARE REQUIRED:
P/N: 11511 - #8-32 x 1/4" LONG PAN HEAD SCREW
(2 REQUIRED PER DIVIDER)

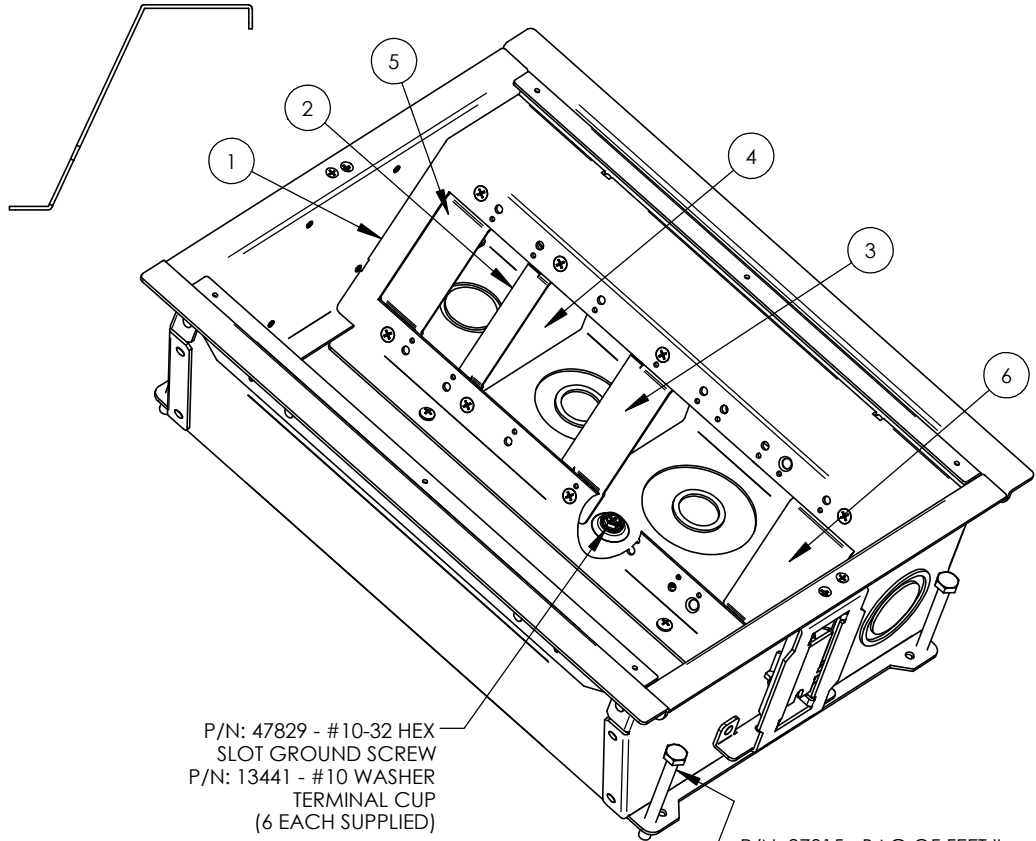

P/N: 47829 - #10-32 HEX
SLOT GROUND SCREW
P/N: 13441 - #10 WASHER
TERMINAL CUP
(6 EACH SUPPLIED)

P/N: 27015 - BAG OF FEET II
(1 BAG OF 4 FEET SUPPLIED)



5 P/N: 55865 - NARROW GANG SPACER (2 SUPPLIED)
HARDWARE REQUIRED:
P/N: 13330 - #8-32 x 1/4" LONG FLAT HEAD SCREW
(2 REQUIRED PER SPACER)



6 P/N: 55864 - WIDE GANG SPACER 1 SUPPLIED
HARDWARE REQUIRED:
P/N: 13330 - #8-32 x 1/4" LONG FLAT HEAD SCREW
(2 REQUIRED PER SPACER)

B

B

A

A

4

3

2

1

NOTE: SUPPLIED QUANTITY COUNT
REFERS TO QUANTITY
SHIPPED WITH BOX.

FSR inc.
244 BERGEN BLVD.
WOODLAND PARK, NJ 07424
TEL (973) 785-4347
FAX (973) 785-3318

TITLE: FL-400-5-B SPARE PARTS LIST			
DRAWN BY: JRE	DATE: 11/10/21	REV: -	
DWG#: FL-400-5-B spare parts			SCALE: 1:1