

# SkyBox™ Series

## SB-50/SB-200/SB-HATCH

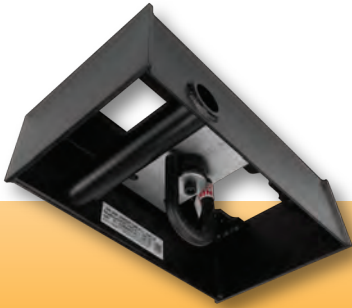

Metal Products Group



SB-200

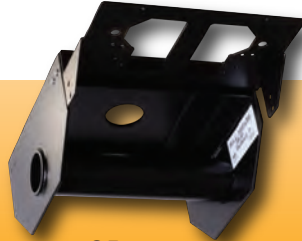

SB-50



SB-HATCH

### DESCRIPTION

The SkyBox rigging point is designed to create a permanent rigging point for trusses, lighting systems, line arrays, and speakers in multi-use architectural environments. The SkyBox handles the rigors of daily staging events but can remain out of view when not in use.

The SkyBox structurally mounts above the ceiling grid and is easily exposed for use by removing the ceiling tile or opening the SB-HATCH doors. When not in use simply return the tile or close the doors, and the SkyBox will be hidden from view.

The SB-50 contains an integrated 1.5" pipe, which functions as a rigging point for lighting, trusses, and speakers. An optionally installed bracket provides mounting for two standard 4" electrical boxes to handle your power and control requirements. W.L.L. 1000 LBS.

The SB-200 contains an integrated swivel hoist ring and a 1.5" pipe, which functions as a rigging point for lighting fixtures, trusses, line arrays and other rigging needs. It also integrates locations for two standard 4" electrical boxes to handle multiple locations for your power and control requirements. Tube W.L.L. 1000 LBS. Hoist Ring W.L.L. 2,300 LBS. Combined W.L.L. 2,300 LBS.

The SB-Hatch provides bomb-bay door access to any of SkyBox rigging points. The Hatch provides an architecturally pleasing method of access without the need to touch any ceiling tiles.

### FEATURES

- Shallow (5") structurally-rated box for limited vertical space requirements.
- Can be mounted flush with the ceiling surface when equipped with an access hatch or cover directly below.
- Standard 1.5" Trade Size pipe serves as a light pipe and load-rated rigging point.
- The box can accommodate several lighting power connectors.
- Mounting Locations for Four Standard 4" Electrical Boxes.
- Designed to be visually concealed when not in use
- Accommodates standard lighting fixture pipe clamps and connections.

### APPLICATIONS

- Ballrooms
- Houses of Worship
- Lobbies
- Multi Purpose Architectural Spaces
- Atriums
- Shopping Malls

### FSR Inc.

244 Bergen Boulevard, Woodland Park, NJ 07424  
Phone: 973.998.2300 · Fax: 973.785.4207  
Web: [www.fsrinc.com](http://www.fsrinc.com) · E-mail: [sales@fsrinc.com](mailto:sales@fsrinc.com)  
Toll Free: 1-800-332-FSR1

LIT1653A

# DIMENSIONS

## SB-50

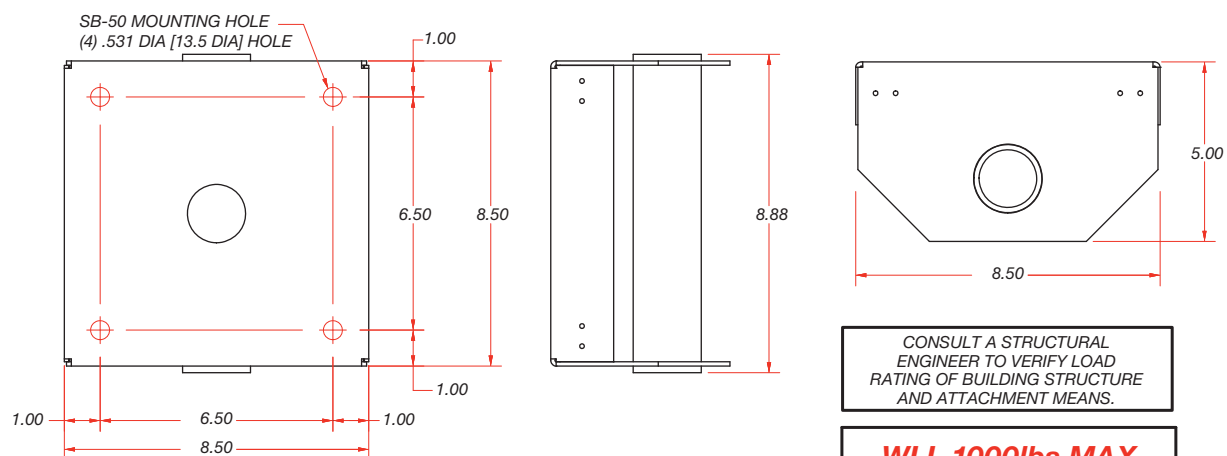

CONSULT A STRUCTURAL ENGINEER TO VERIFY LOAD RATING OF BUILDING STRUCTURE AND ATTACHMENT MEANS.

**WLL 1000lbs MAX**

COMBINED LOAD OF ALL LIGHTING/EQUIPMENT ATTACHED TO SB-50'S CENTER CROSS TUBE MUST NOT EXCEED 1,000 LBS.

ATTACH BRACKET AS REQUIRED. BRACKET CAN BE MOUNTED ON ANY 4 SIDES OF BOX, IN 2 ORIENTATIONS. HARDWARE FOR BRACKET AND MOUNTING ELECTRICAL BOXES (SOLD SEPARATELY) ARE SUPPLIED.

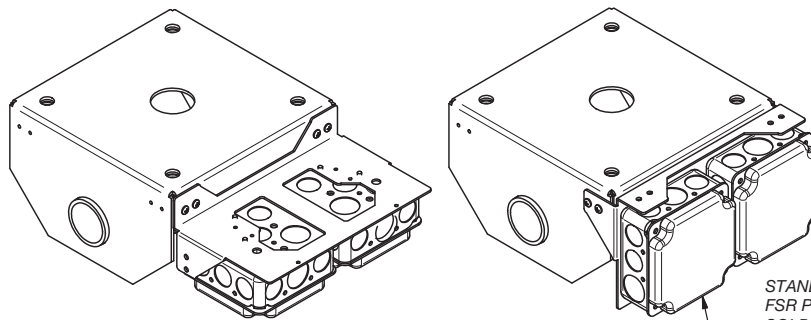

STANDARD RACO 8192 ELECTRICAL BOX  
FSR P/N 48771 (2 BOXES SHOWN -  
SOLD SEPARATELY)

# DIMENSIONS

## SB-200

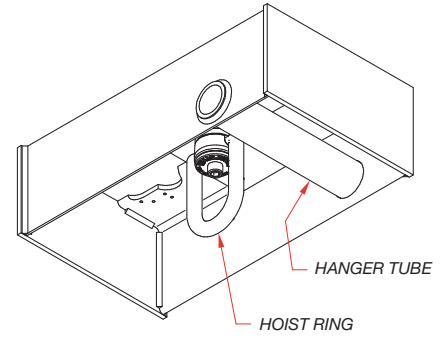
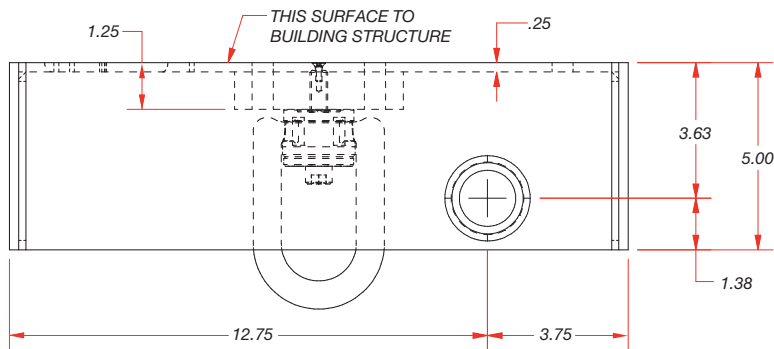

STANDARD BS 4662 72mm SQ (SHOWN) OR STANDARD BS 4662 135mm x 75mm SQ ELECTRICAL BOX (EURO BOX) (SOLD SEPARATELY) 6x ø.56 MOUNTING HOLE

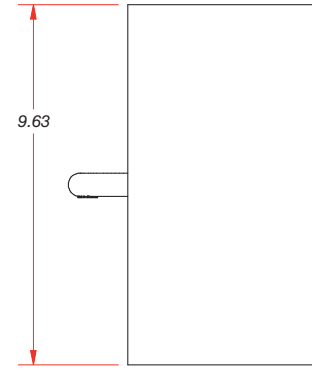
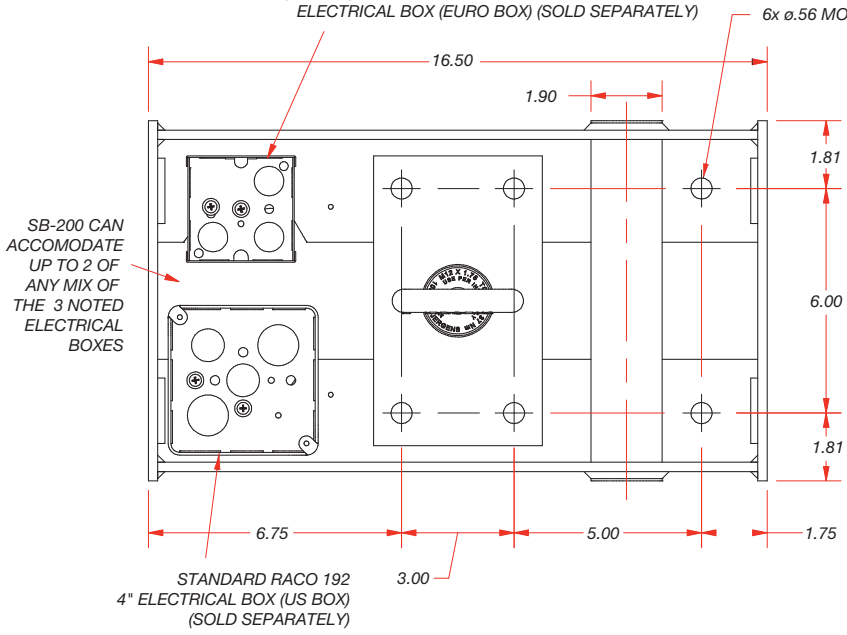

**HANGER TUBE** W.L.L. 1,000 LBS.  
**HOIST RING** W.L.L. 2,300 LBS.  
**COMBINED** W.L.L. 2,300 LBS.

CONSULT A STRUCTURAL ENGINEER TO VERIFY LOAD RATING OF BUILDING STRUCTURE AND ATTACHMENT MEANS.

# DIMENSIONS

## SB-HATCH

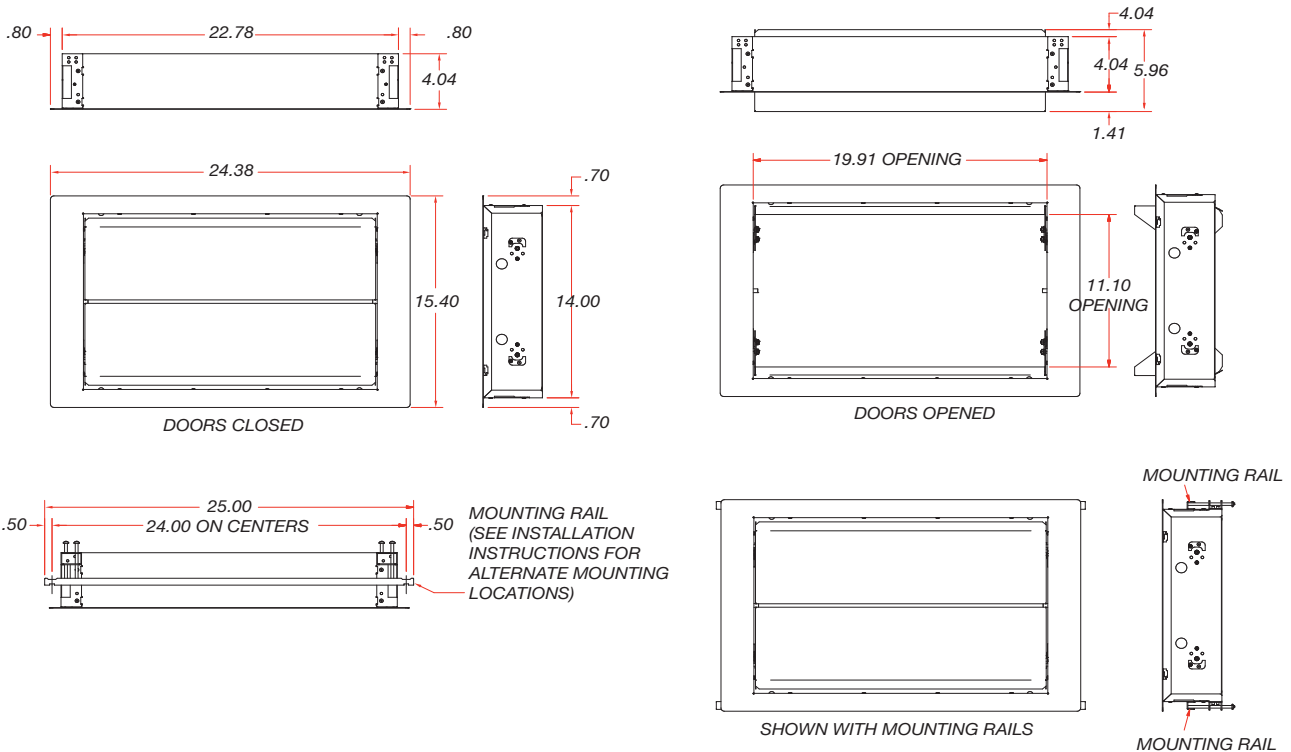

244 Bergen Boulevard, Woodland Park, NJ 07424  
 Phone: 973.998.2300 · Fax: 973.785.4207  
 Web: [www.fsrinc.com](http://www.fsrinc.com) · E-mail: [sales@fsrinc.com](mailto:sales@fsrinc.com)



Specifications are subject to change without notice.