

8. ROUTE FITTINGS AS REQUIRED TO FLOOR BOX.

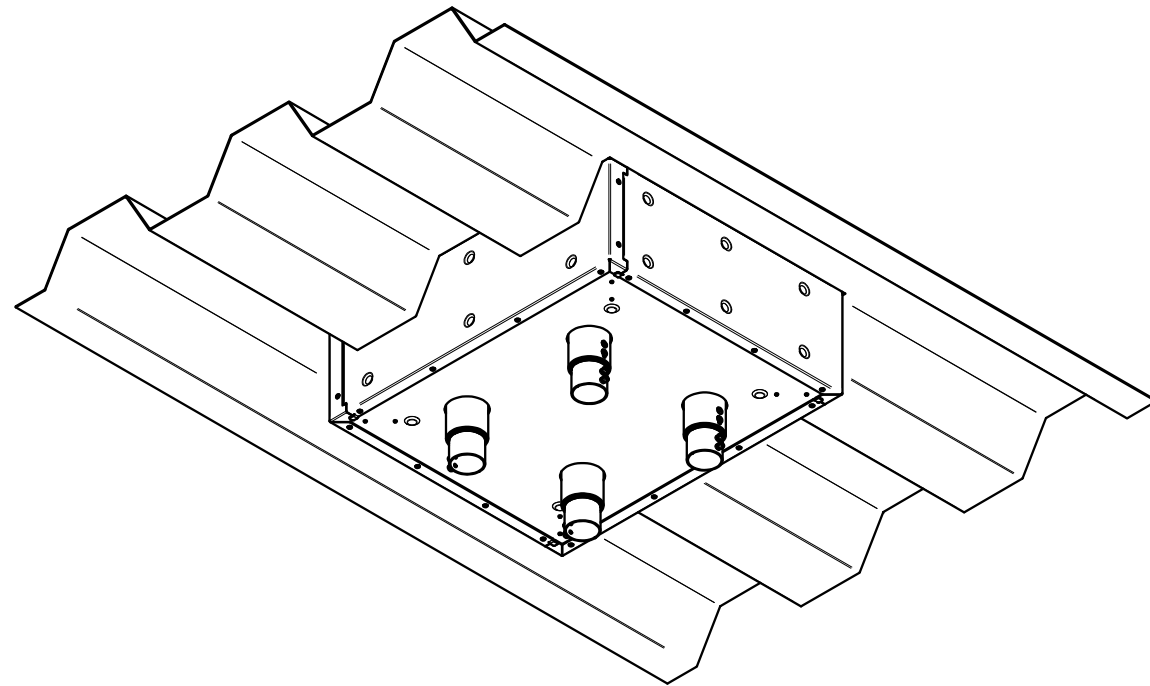

9. PULL WIRES AND CABLES TO BOX AS NECESSARY (CONFIGURING OF GANG MOUNTING BRACKETS MAY BE REQUIRED - REFER TO FLOOR BOX INSTALLATION INSTRUCTIONS). TERMINATE WIRES AND CABLES TO ELECTRONIC COMPONENTS, AND INSTALL ELECTRONIC COMPONENTS ONTO GANG MOUNTING BRACKETS. REINSTALL TEMPORARY COVER IF FINISHED COVER IS TO BE INSTALLED AT A LATER DATE.

NOTE: FOR USE WITH A MAXIMUM CONDUCTOR SIZE OF 10 AWG.

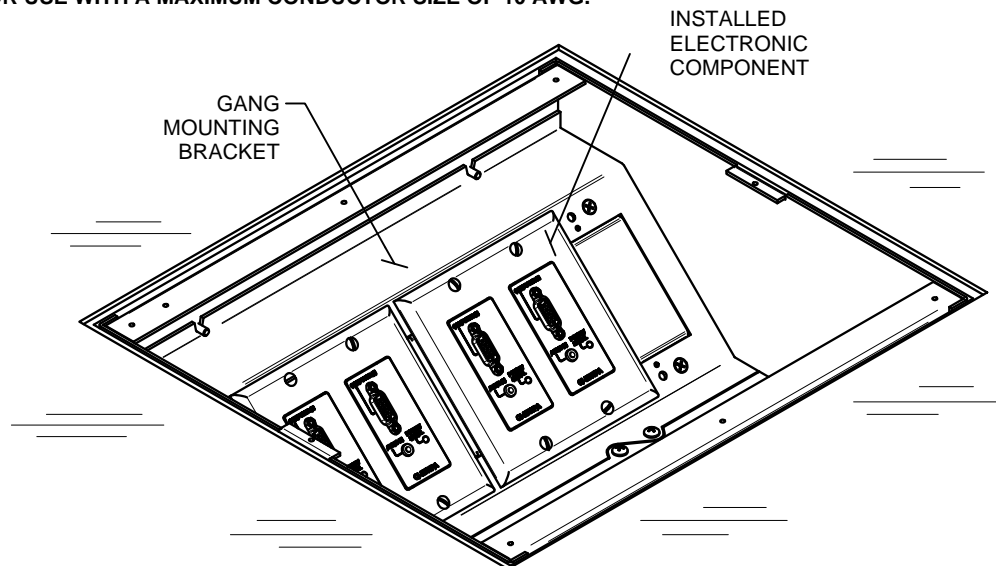

FSR FL-FRK-605P INSTALLATION INSTRUCTIONS FOR CORRUGATED OR FORMED DECK

244 Bergen Boulevard, Woodland Park, NJ 07424, Phone: 973.785.4347 - Fax: 973.785.4207

NOTE: READ FLOOR BOX INSTALLATION INSTRUCTIONS PRIOR TO INSTALLATION.

1. PRIOR TO CUTTING THE 17-1/4" x 20" OPENING IN THE DECK SURFACE, REFER TO CUSTOMER SPECIFICATIONS FOR ORIENTATION OF FLOOR BOX. ORIENTATION OF OPENING WILL BE BASED ON ORIENTATION OF PAN (SEE LABEL IN PAN BOTTOM).

NOTE: CONSULT STRUCTURAL ENGINEER BEFORE CUTTING DECKING. ADD ADDITIONAL SUPPORTS AS REQUIRED PER ENGINEERING INSTRUCTIONS.

OUTLET BOXES AND FITTINGS CERTIFIED FOR FIRE RESISTANCE

TYPE FL-FRK-500P-N AND FL-FRK-605P-N PRESET ELECTRICAL INSERTS FOR USE WITH TYPE FL-500P-++C OR FL-600P-++C SERVICE FITTING COVERS FOR USE IN 1, 1-1/2, 2, OR 3 HR RATED UNPROTECTED REINFORCED CONCRETE FLOORS AND IN 1, 1-1/2, 2 OR 3 HR RATED FLOORS EMPLOYING UNPROTECTED STEEL FLOOR UNITS AND CONCRETE TOPPING (D900 SERIES FLOOR-CEILING DESIGNS CONSTRUCTED WITH NOMINAL 2 IN. (51mm) OR 3 IN. (76mm) DEEP FLUTED STEEL FLOOR UNITS HAVING NOMINAL 5 IN. (127mm) WIDE VALLEYS AND CRESTS SPACED 12 IN. (305mm) OC.), OR CONCRETE FLOORS WITH SUSPENDED CEILING. (FIRE RESISTANCE DESIGNS WITH SUSPENDED CEILINGS SHOULD HAVE PROVISIONS FOR ACCESSIBILITY IN THE CEILING AREA BELOW THE PRESET ELECTRICAL FITTINGS.) THE PRESET ELECTRICAL INSERTS ARE FOR USE WITH A MINIMUM 3-1/4 IN. (83mm) THICKNESS OF STRUCTURAL CONCRETE TOPPING. FOR USE WITH A MAX OF SIXTY (60) NO. 14 AWG SOLID TYPE THHN CONDUCTORS. THE ASSEMBLED PRESET ELECTRICAL INSERT WITH FLOOR PLATE KIT AND SERVICE ACTIVATION FITTING WILL NOT REDUCE THE 3 HR FIRE RATING OF THE FLOOR ASSEMBLY WHEN INSTALLED IN ACCORDANCE WITH THE INSTALLATION INSTRUCTIONS ACCOMPANYING THE PRESET ELECTRICAL INSERT AND WHEN THE PRESET ELECTRICAL INSERTS ARE SPACED MINIMUM 2 FT (610mm) OC WITH NOT MORE THAN ONE DEVICE PER EACH 65 SQ. FT. (6.04 m2) OF FLOOR AREA.

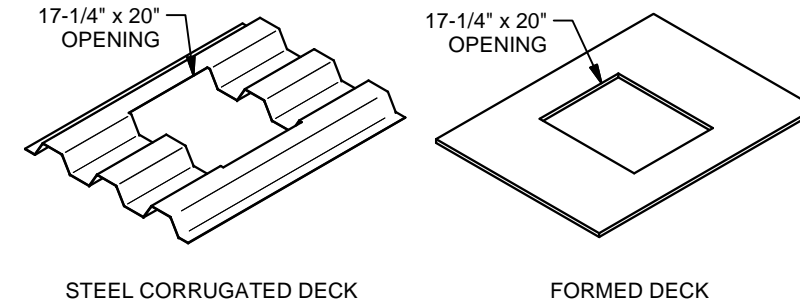

NOTE: FOR CORRUGATED DECK PAN MUST BE CENTERED ON PEAK OR VALLEY.

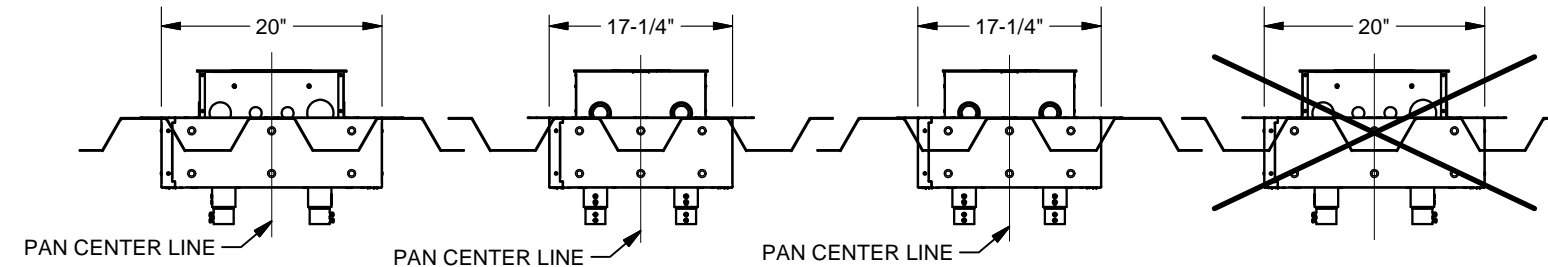

2. INSTALL PAN IN CUT-OUT AND SECURE TO DECKING WITH HARDWARE (BY OTHERS) OR WELDING.

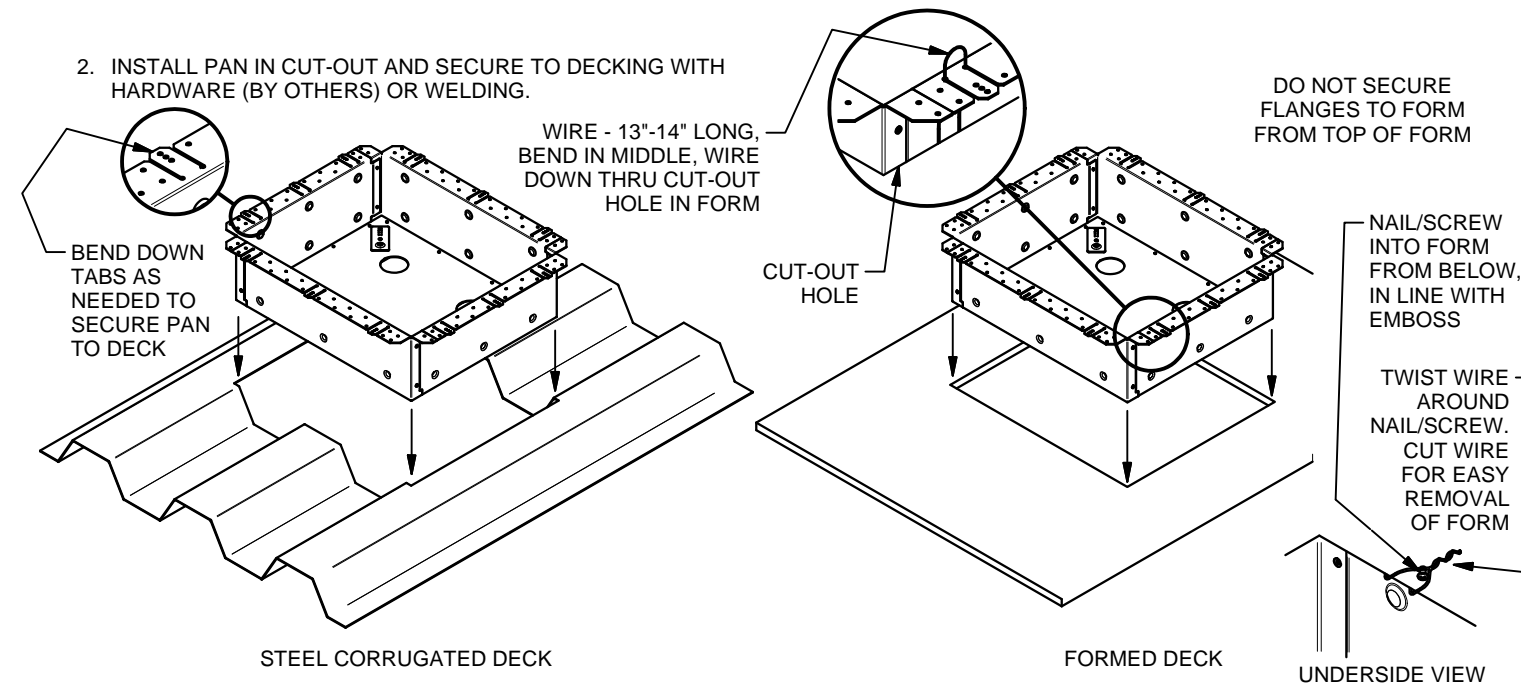

3. REMOVE AND RETAIN TEMPORARY COVER AND SCREWS.

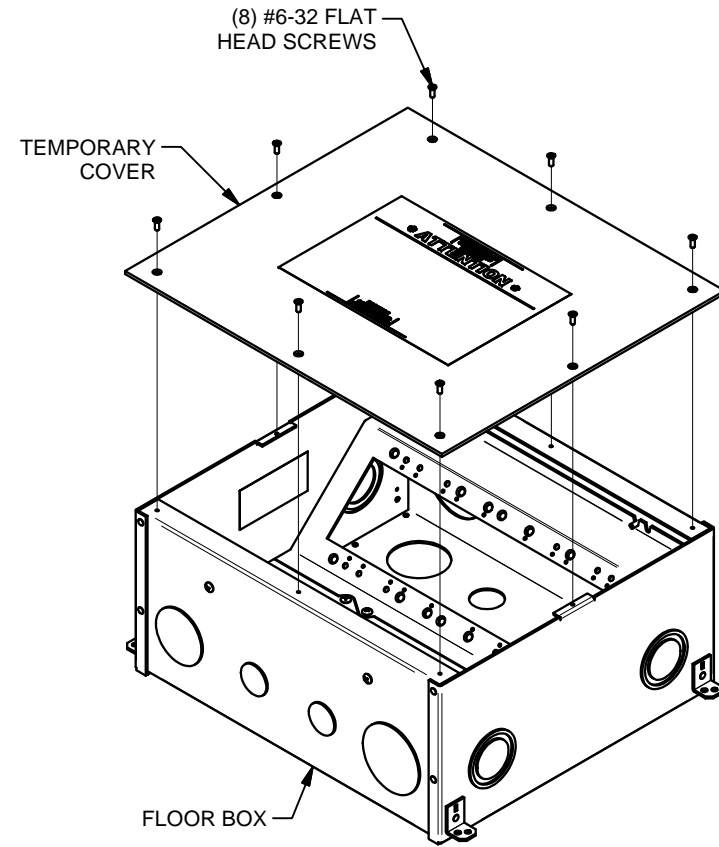

4. REMOVE (4) 1-1/2" KNOCKOUTS LOCATED ON BOTTOM OF FLOOR BOX. **ALL OTHER KNOCKOUTS IN THE BOX ARE NOT TO BE USED OR REMOVED.**

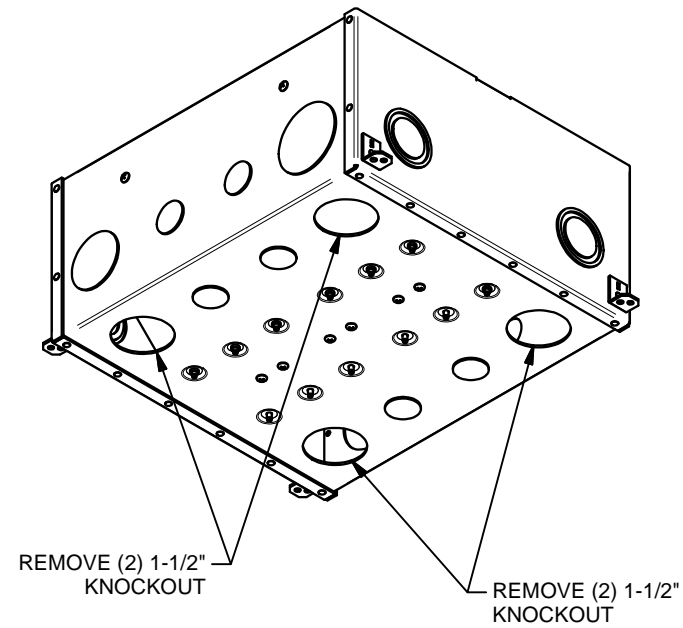

5. INSTALL INTUMESCENT-LINED FITTING AND FLOOR BOX LEVELING BOLTS AS SHOWN.

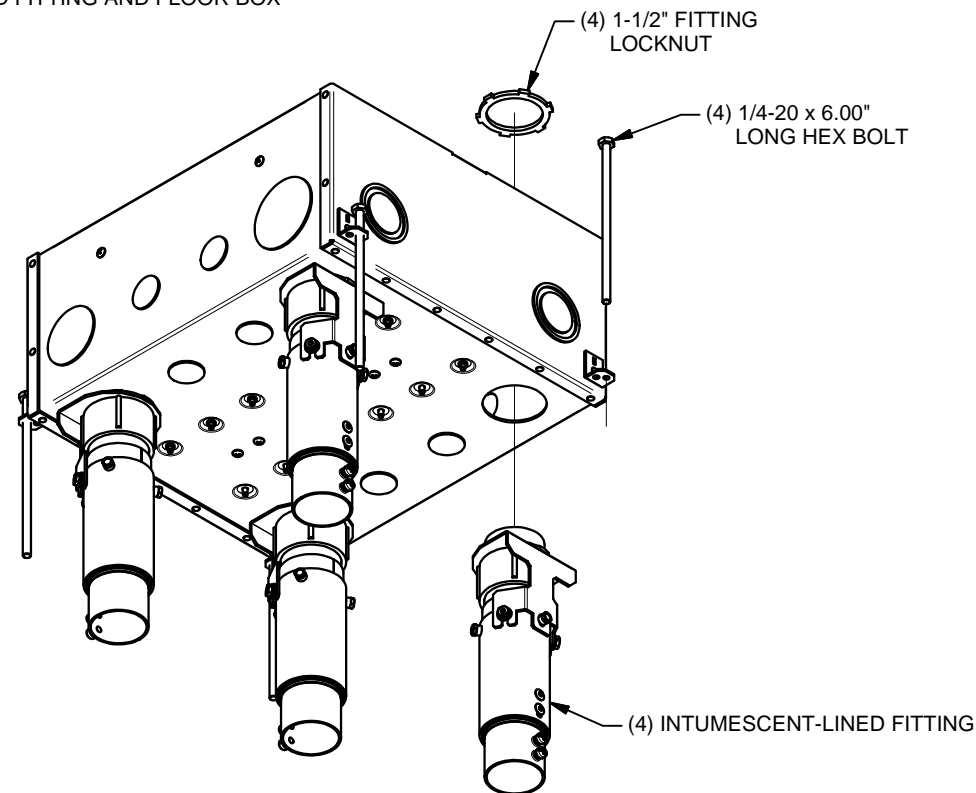

6. INSTALL FLOOR BOX INTO PAN. LEVEL BOX TO PROPER HEIGHT WITH LEVELING BOLTS. ANCHOR BOX USING WIRE (SUPPLIED BY OTHERS) TO PREVENT BOX FROM FLOATING DURING POUR.

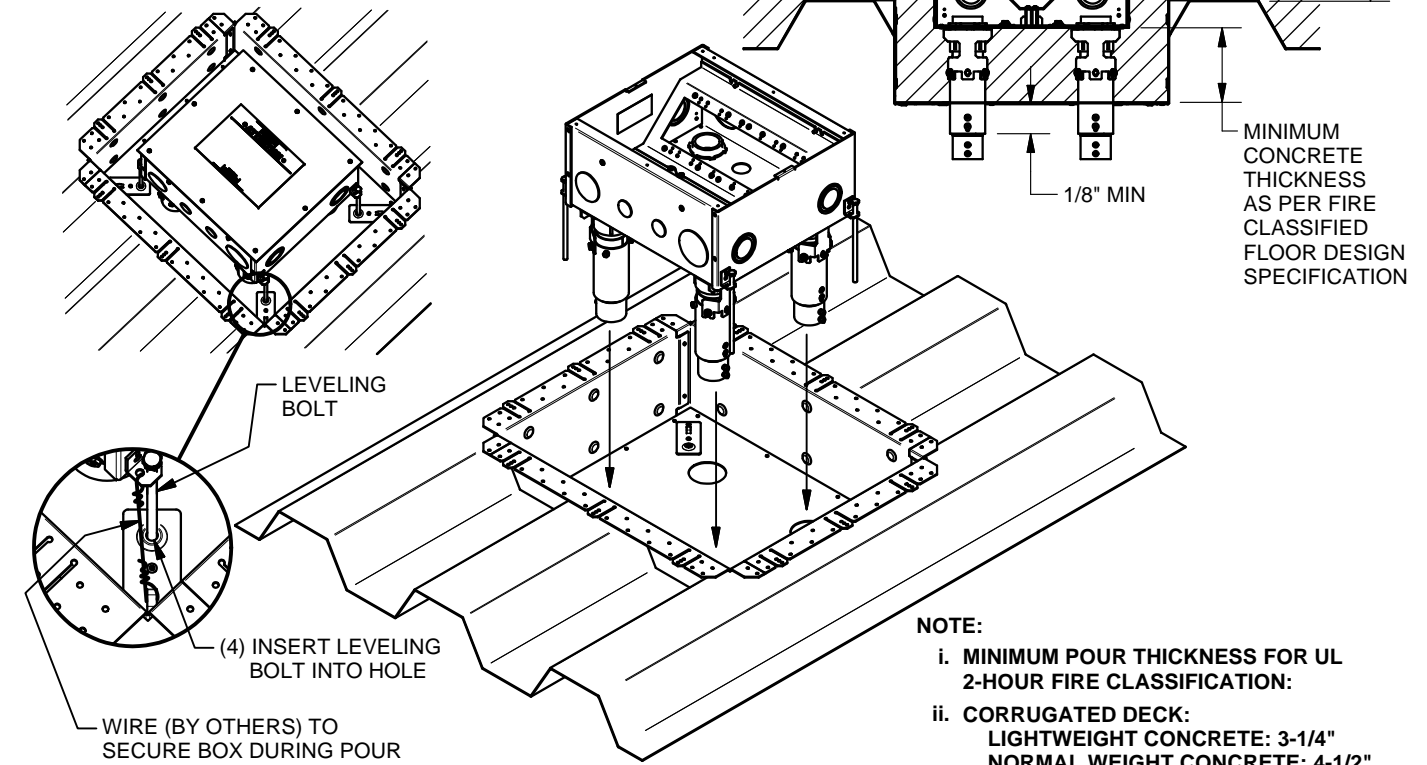

NOTE:

- i. MINIMUM POUR THICKNESS FOR UL 2-HOUR FIRE CLASSIFICATION:
- ii. CORRUGATED DECK:
LIGHTWEIGHT CONCRETE: 3-1/4"
NORMAL WEIGHT CONCRETE: 4-1/2"
- iii. FORMED DECK:
LIGHTWEIGHT CONCRETE: 3-3/4"
NORMAL WEIGHT CONCRETE: 5"
- iv. WITH USER SUPPLIED LONGER THREADED ROD: DIM "A" = 6.00 MAX

7. **GANG BRACKET SCREWS AND GROUND SCREWS MUST BE IN PLACE AND BOTTOMED TO ENSURE SCREW VOIDS AFTER POUR.** REINSTALL TEMPORARY COVER. FILL VOIDS BETWEEN DECK CUT-OUT HOLE AND PAN WITH TAPE OR CAULK TO PREVENT CONCRETE LEAKAGE WHILE POURING. DURING POUR, A VIBRATORY TOOL MUST BE USED TO ENSURE COMPLETE FILL OF CONCRETE SURROUNDING THE FLOOR BOX WITHIN THE PAN ASSEMBLY.

