

1. DETERMINE LOCATION AND CUT 7.50 x 6.50 HOLE WITH 1/4 MAX RADIUS CORNERS IN TABLE TOP.

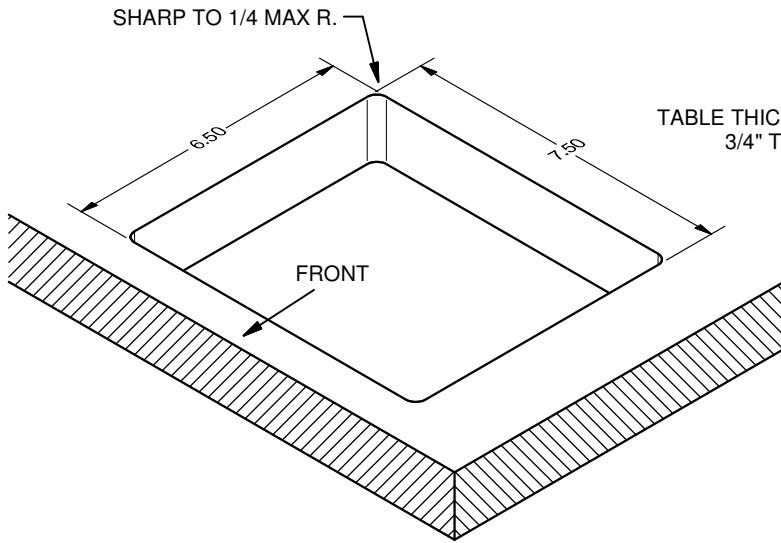

2. INSTALL DESIRED POWER UNITS/INTERNAL BRACKETS INTO RT6-S4 ASSEMBLY. ADJUST HEIGHT OF UNITS/BRACKETS IN RT6-S4 ASSEMBLY BEFORE INSTALLING IN THE TABLE. FOLLOW THE UNIT/BACKET INSTALLATION INSTRUCTIONS WHEN PROVIDED. IF RETRACTORS WILL BE INSTALLED, LEAVE THAT COMPARTMENT OPEN; RETRACTORS WILL BE ASSEMBLED LATER INTO A CASSETTE THEN INSTALLED FROM BOTTOM.

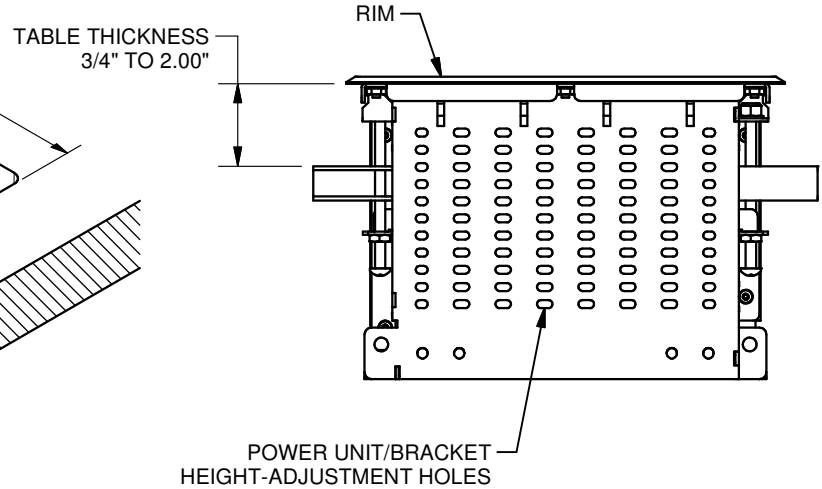

3. ROTATE LOCKING ARMS CLEAR OF TABLE AND INSERT RT6-S4 ASSEMBLY INTO HOLE OF TABLE.

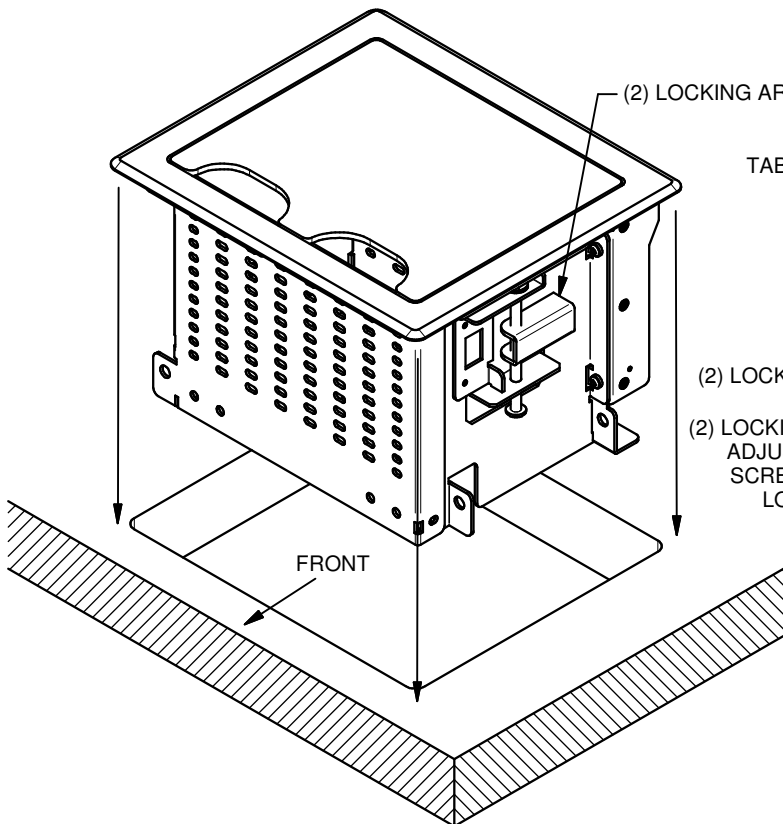

4. ROTATE LOCKING ARMS TO SECURE ASSEMBLY TO TABLE WITH ADJUSTMENT SCREW. LOCK ADJUSTMENT SCREW WITH INTEGRAL NUT WHERE NEEDED. MAKE ELECTRICAL CONNECTIONS AS REQUIRED.

