

4" Black  
Cable Tie

### Charging Station Wiring Instructions

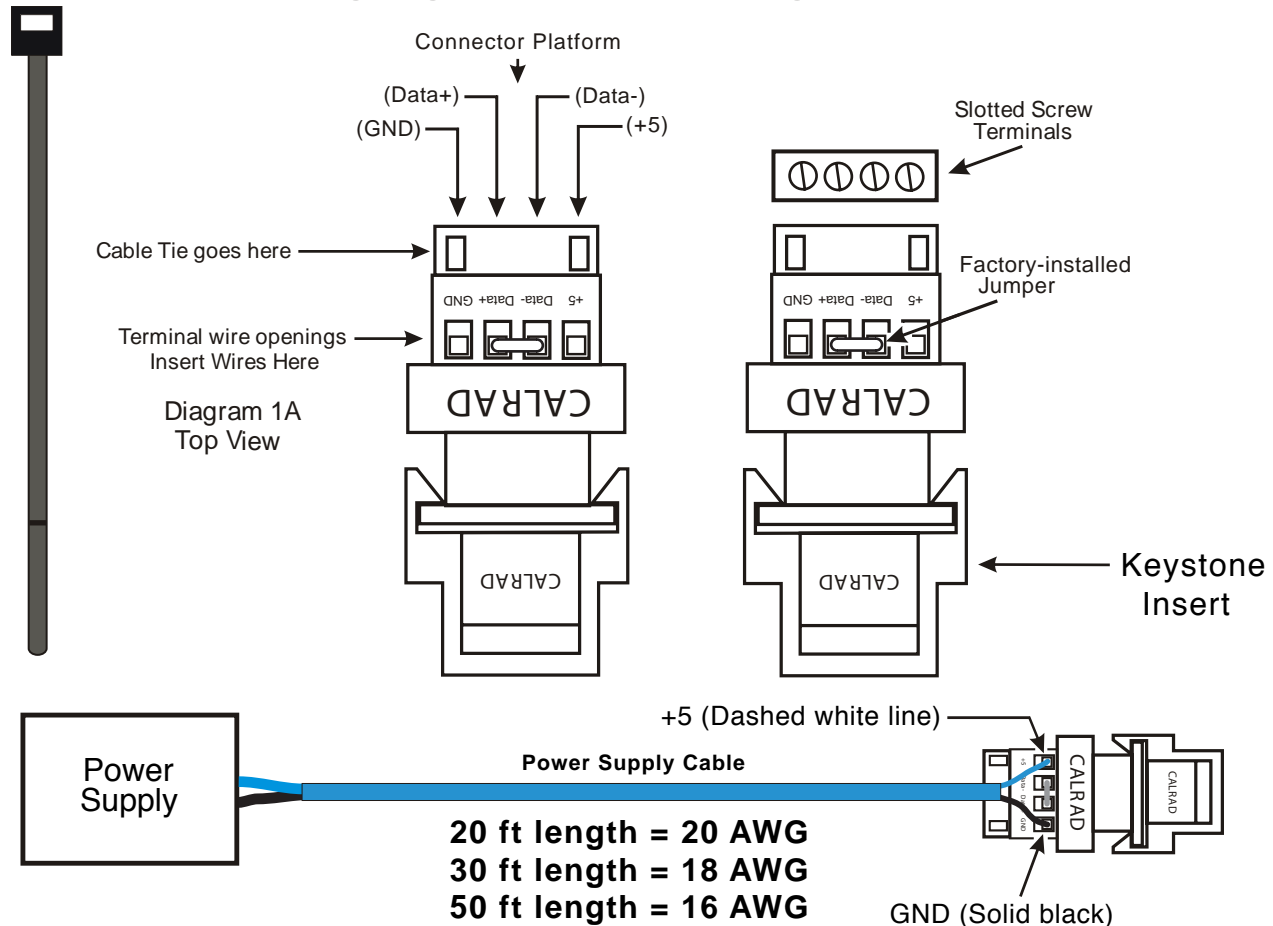

#### Installation Instructions:

The solderless 'Keystone' female USB Type A jack comes preconfigured for 'charging station' applications. A 'short' from D+ to D- indicates to a portable device that it is connected to a dedicated charging station and it's allowed to draw the high current required for such applications.

The power supply that's provided with the jack has a 9-foot-long output cord. In applications requiring the supply to be located more than this distance from the jack, you will need to extend the output cable by attaching the appropriate-gauge wire for the length required. Observe the wire gauge and length noted above, or high-current portable devices may not have sufficient voltage to charge, and will display an error message.

In all installations, it is advisable to use the shortest length of the heaviest specified gauge wire to ensure compatibility with the widest range of devices.

#### Power Supply Preparation:

- 1) Cut the output connector off the end of the power supply wiring, if so equipped, and strip the wire insulation approximately 1/4". If the application requires extending the power supply cable length beyond the 9 feet provided, cut the output cable to the minimum practical length (no longer than 8 inches), and refer to the wire lengths above for the maximum permissible length of extension wire. Solder and tape/shrink tube or use appropriate-size wire nuts to connect the power supply wires to the extension wires.
- 2) Connect the power supply wire with the dashed white line (or it's added extension wire) to the +5 screw terminal. Connect the solid black wire (or it's added extension wire) to the GND screw terminal.