

WB-X3-GNG

STEPS:

1. REMOVE ASSEMBLED MOUNTING PLATES FROM CHASSIS AS SHOWN IN FIGURE 1, SETTING PLATE AND SCREWS ASIDE.
2. REMOVE UPPER/LOWER GANG-UNIT END FROM CHASSIS AS SHOWN IN FIGURE 2, SETTING GANG-UNIT ENDS AND SCREWS ASIDE.
3. INSTALL CHASSIS INTO WALL PER INSTRUCTIONS AT THE END OF THIS DOCUMENT.
4. ROUTE CONDUITS TO CHASSIS, AND PULL WIRES AS REQUIRED.
5. GANG-UNIT END SEPARATOR IS MOVEABLE SIDE-TO-SIDE OF CENTER OF END, OR CAN BE REMOVED ALTOGETHER. AFTER DETERMINATION OF SEPARATOR, REINSTALL GANG-UNIT ENDS AS SHOWN IN FIGURE 2.
6. REINSTALL MOUNTING PLATES AS SHOWN IN FIGURE 1. USE SEPARATOR AS REQUIRED.
7. MAKE ELECTRICAL CONNECTIONS AS REQUIRED.

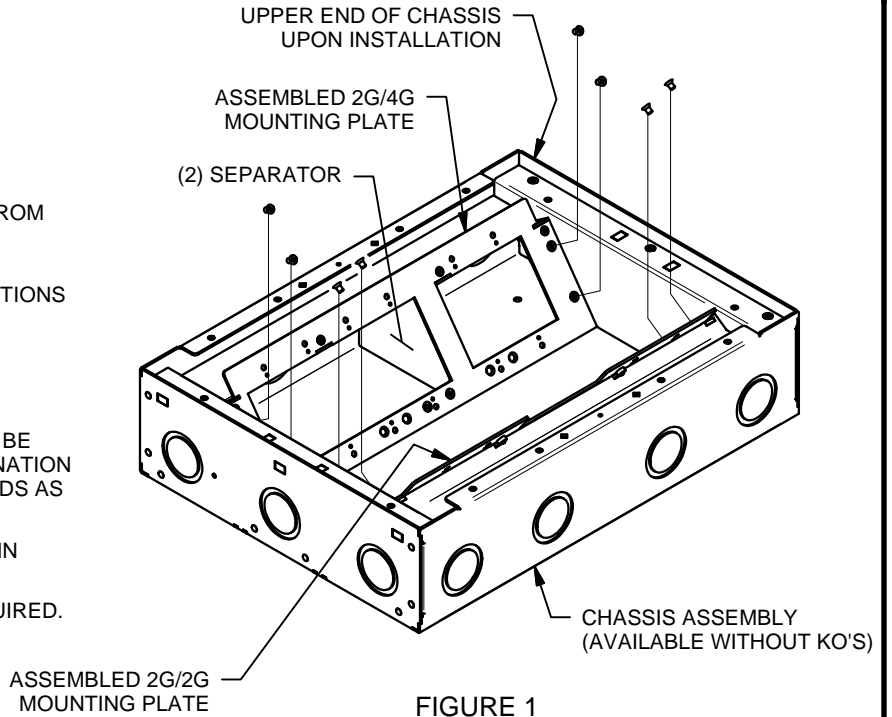

FIGURE 1

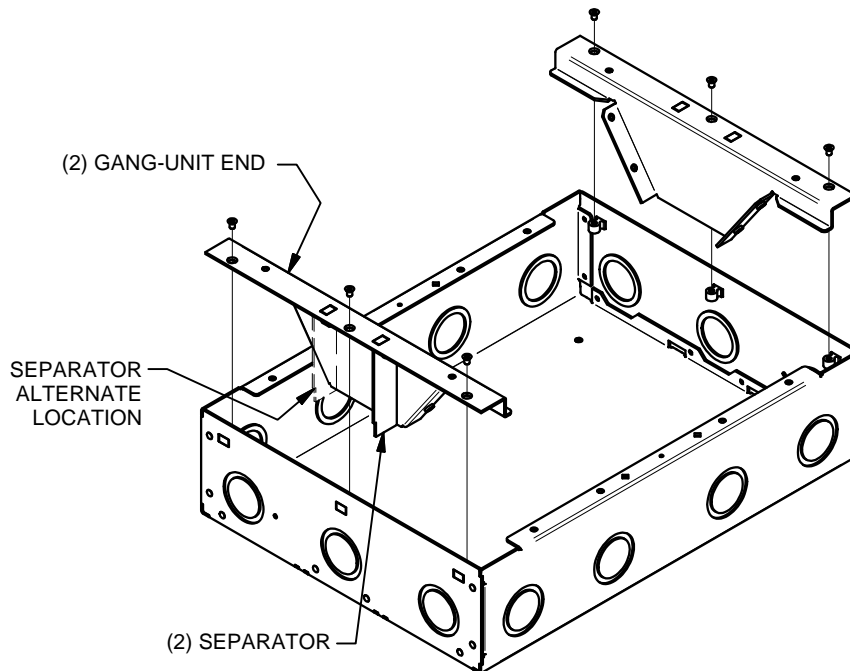

FIGURE 2

STEPS:

1. INSTALL CHASSIS INTO WALL PER INSTRUCTIONS AT THE END OF THIS DOCUMENT.
2. ROUTE CONDUITS TO CHASSIS, AND PULL WIRES AS REQUIRED.
3. ASSEMBLE FRAME ASSEMBLY AS SHOWN IN FIGURE 3.
4. INSTALL FRAME ASSEMBLY AS SHOWN IN FIGURE 4.
5. INSTALL IPS WALLBOX BUCKETS AS SHOWN IN FIGURE 5.
6. MAKE ELECTRICAL CONNECTIONS AS REQUIRED.

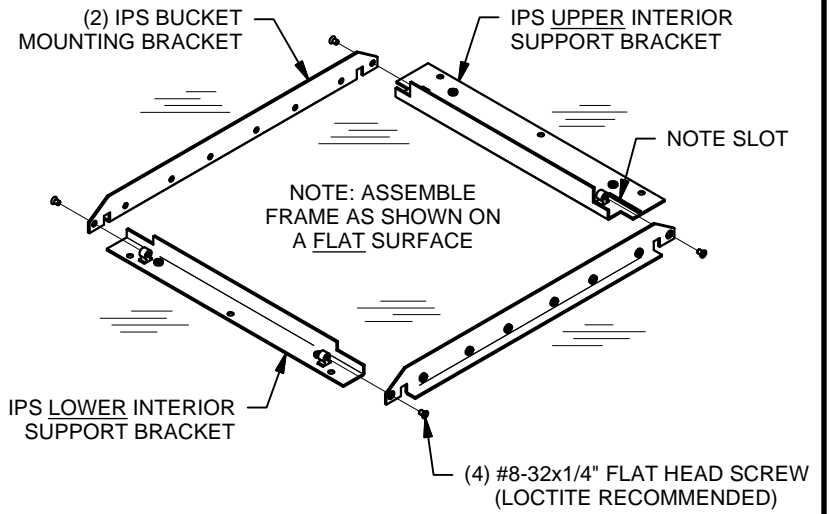

FIGURE 3

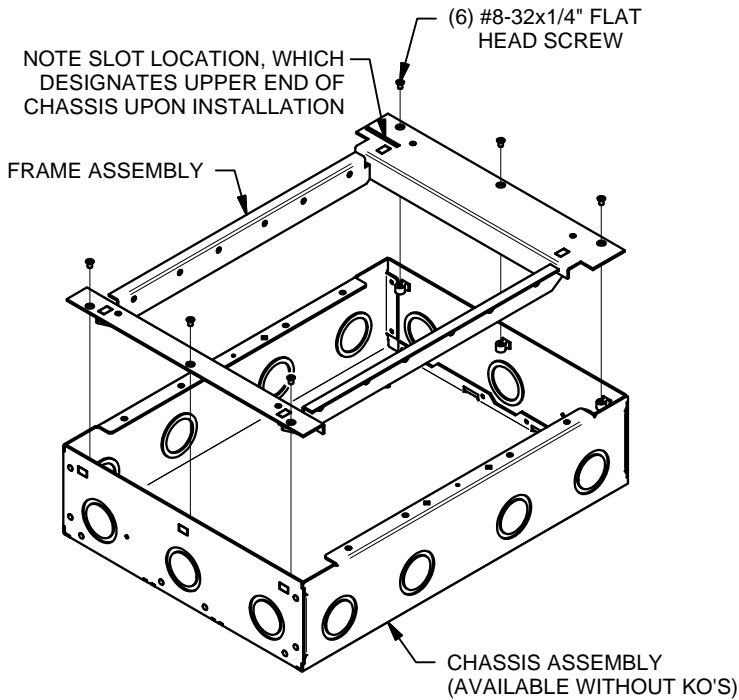

FIGURE 4

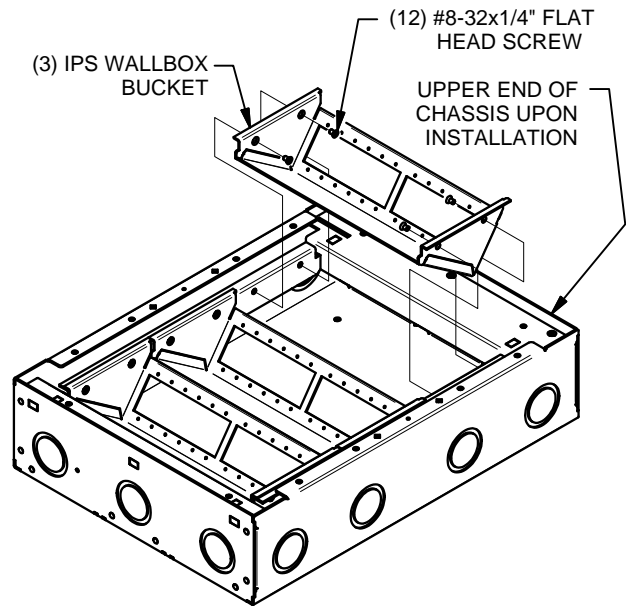

FIGURE 5

STEPS:

1. INSTALL CHASSIS INTO WALL PER INSTRUCTIONS AT THE END OF THIS DOCUMENT.
2. ROUTE CONDUITS TO CHASSIS, AND PULL WIRES AS REQUIRED.
3. ASSEMBLE BRACKET ASSEMBLY AS SHOWN IN FIGURE 6.
4. INSTALL BRACKET ASSEMBLIES AS SHOWN IN FIGURE 7.
5. MODIFY BLANK PLATE AS NECESSARY TO MOUNT DESIRED COMPONENTS. INSTALL THIS PLATE AS SHOWN IN FIGURE 8.
6. MAKE ELECTRICAL CONNECTIONS AS REQUIRED.

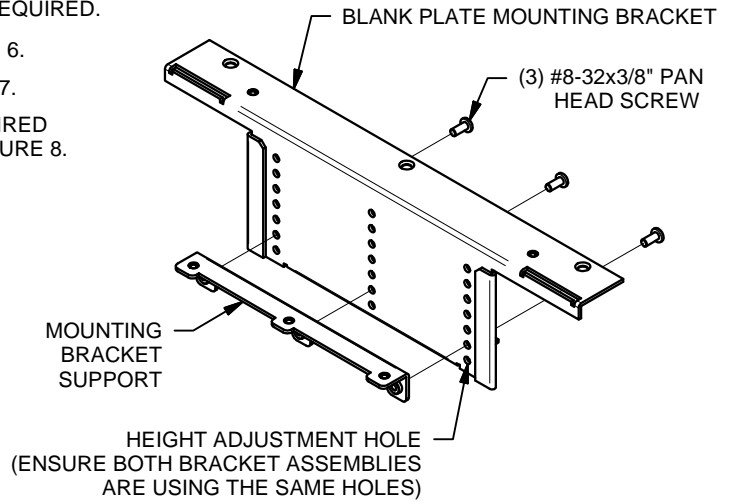

FIGURE 6

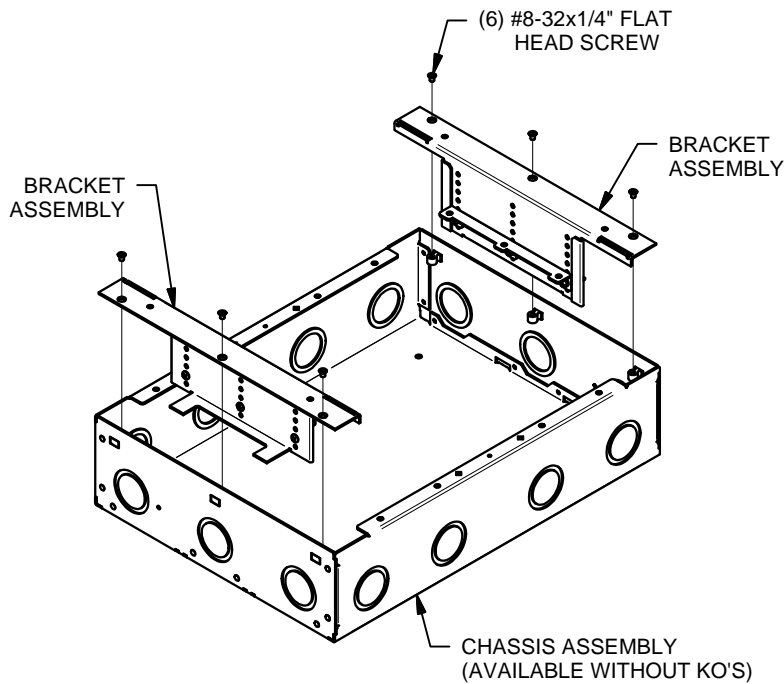

FIGURE 7

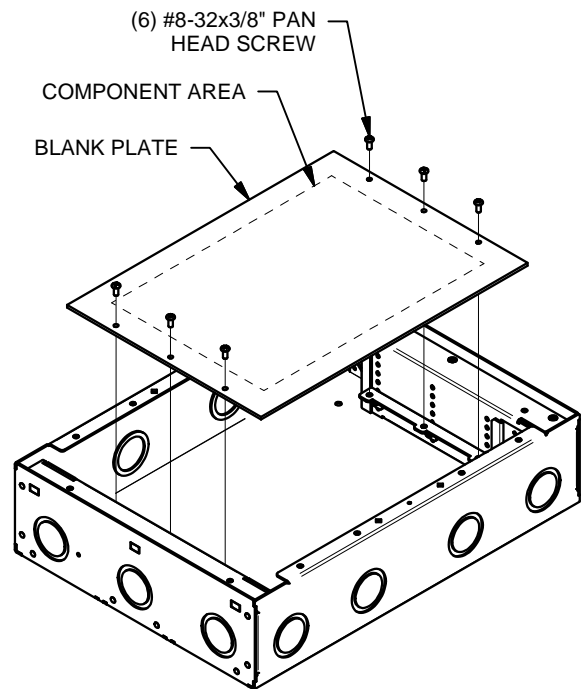

FIGURE 8

STEPS:

1. INSTALL CHASSIS INTO WALL PER INSTRUCTIONS AT THE END OF THIS DOCUMENT.
2. ROUTE CONDUITS TO CHASSIS, AND PULL WIRES AS REQUIRED.
3. ASSEMBLE FRAME ASSEMBLY AS SHOWN IN FIGURE 9.
4. INSTALL FRAME ASSEMBLY AS SHOWN IN FIGURE 10.
5. INSTALL XLR WALLBOX BUCKETS AS SHOWN IN FIGURE 11.
6. MAKE ELECTRICAL CONNECTIONS AS REQUIRED.

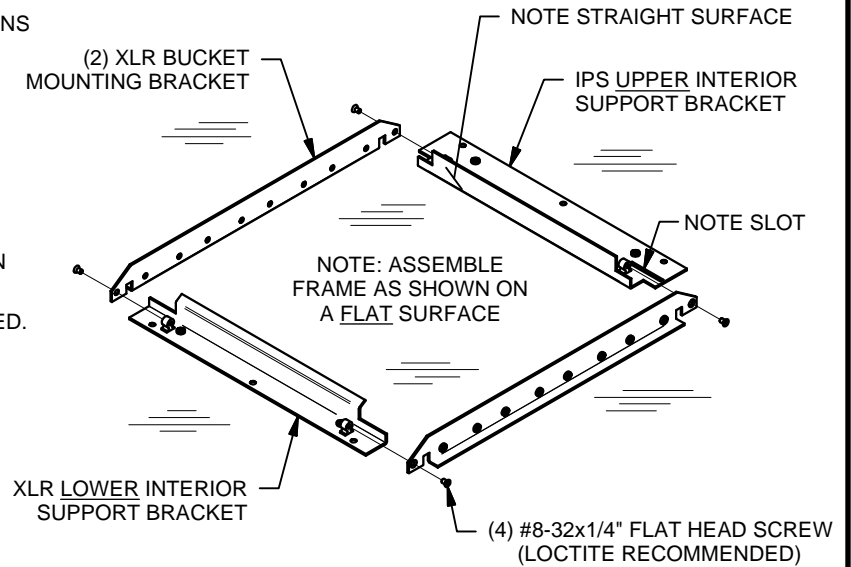

FIGURE 9

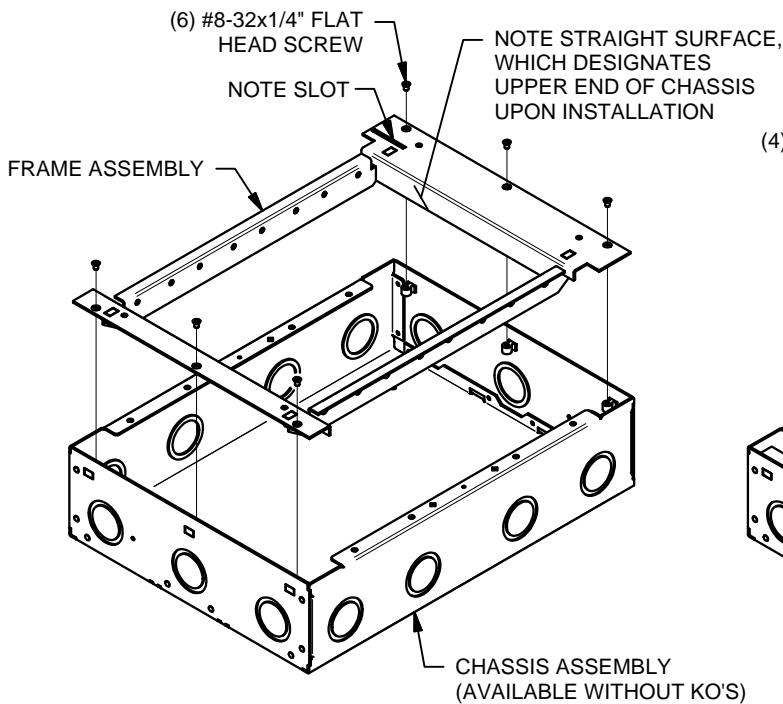

FIGURE 10

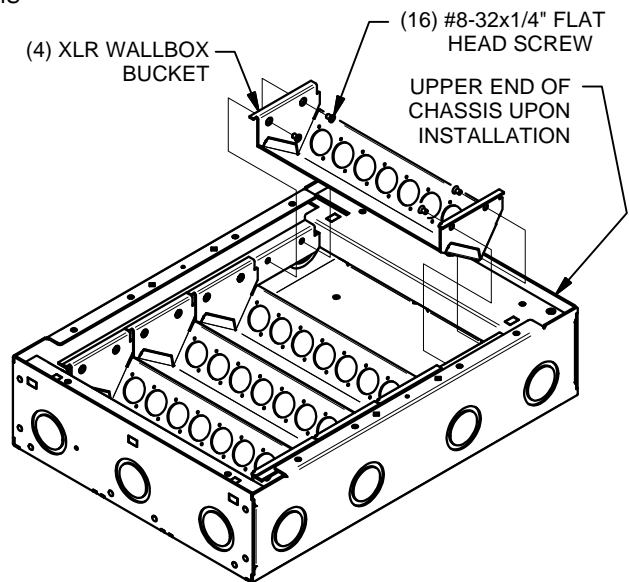

FIGURE 11

WB-X3 INSTALLATION (OLD-WORK)

STEPS:

1. CUT A 12-1/2" x 16-7/8" OPENING IN WALL CENTERED BETWEEN THE STUDS.
2. INSTALL SCREW/CLAMP BLOCK ALONG EDGE OF CUT-OUT AS SHOWN IN FIGURE 12 - SEE STEP 3.
3. ENSURE AT LEAST 3" OF BLOCKING MATERIAL BEYOND BOTH UPPER AND LOWER EDGES OF CUT-OUT.
4. INSTALL OLD-WORK MOUNTING BRACKET TO CHASSIS ASSEMBLY AS SHOWN IN FIGURE 13.
5. MOUNT CHASSIS ASSEMBLY TO WALL AS SHOWN IN FIGURE 14.

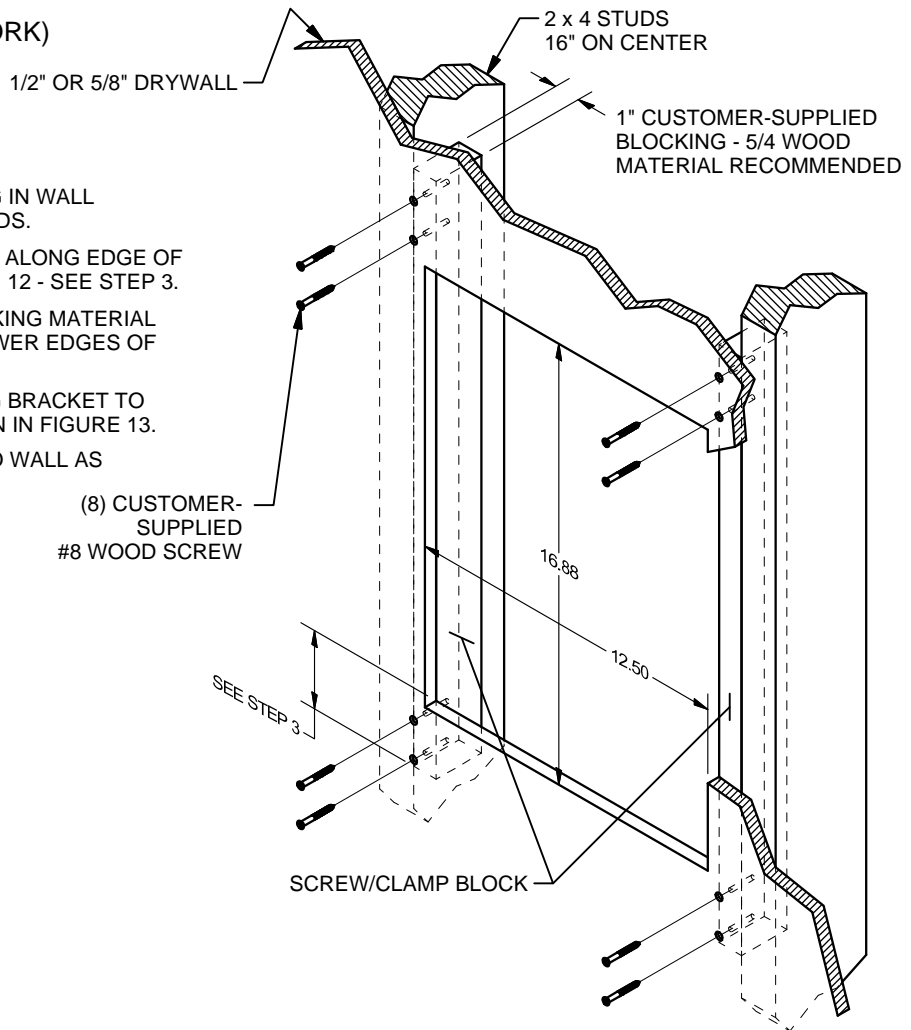

FIGURE 12

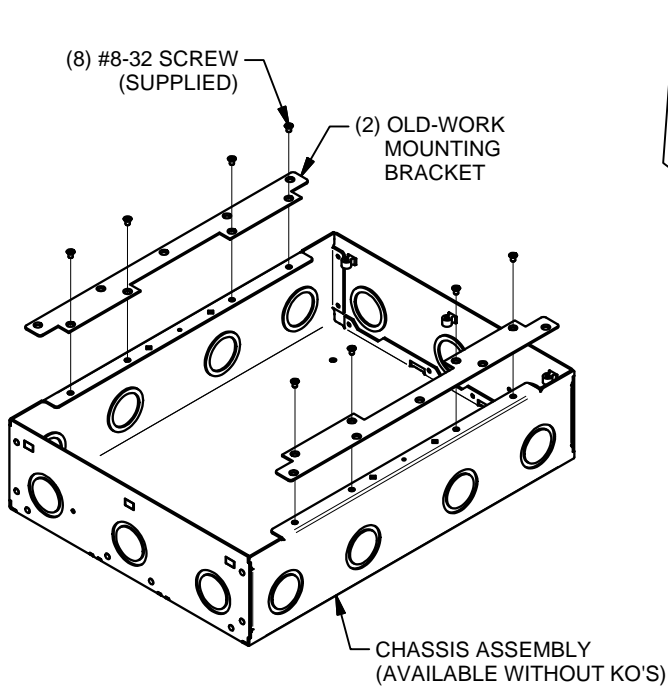

FIGURE 13

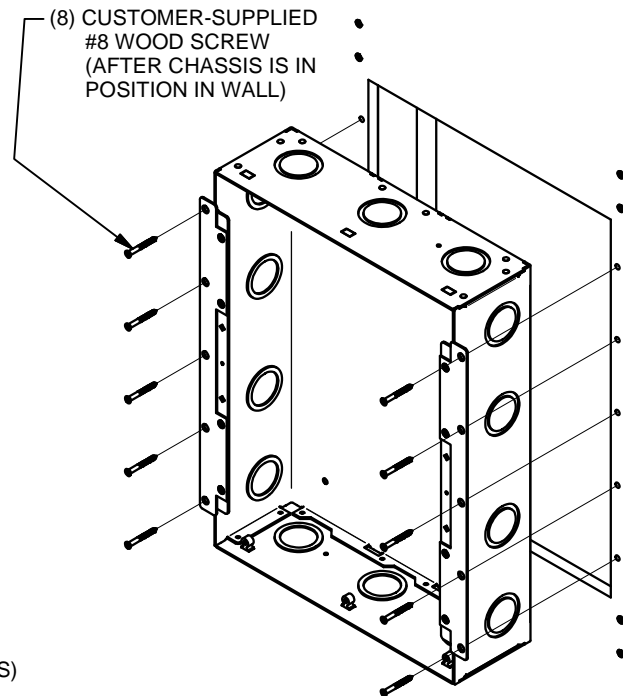

FIGURE 14

WB-X3 INSTALLATION (NEW-WORK)

STEPS:

1. INSTALL (2) MOUNTING BRACKET TO CHASSIS ASSEMBLY AS SHOWN IN FIGURE 15.
2. INSTALL BOX ASSEMBLY ONTO STUDS AS SHOWN IN FIGURE 16.

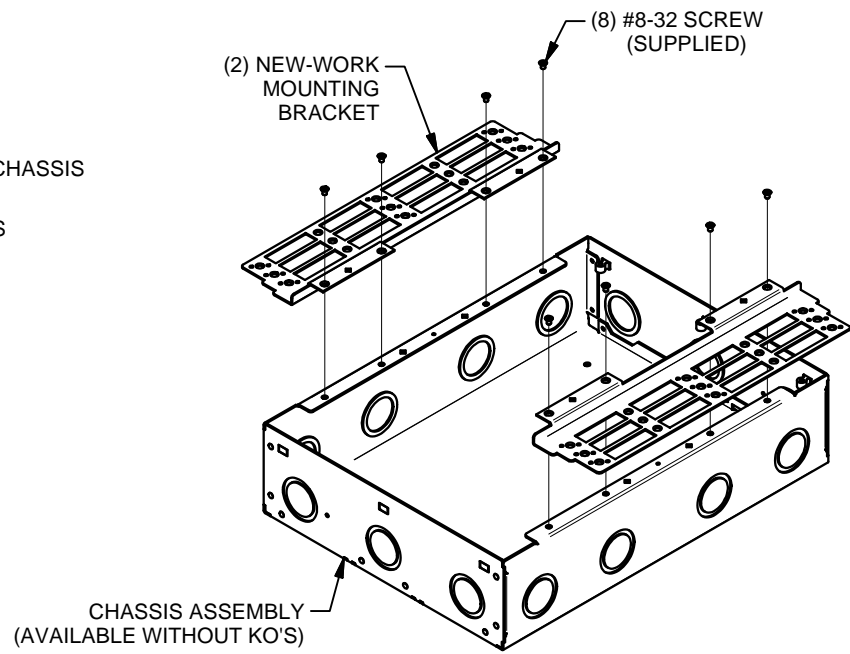

FIGURE 15

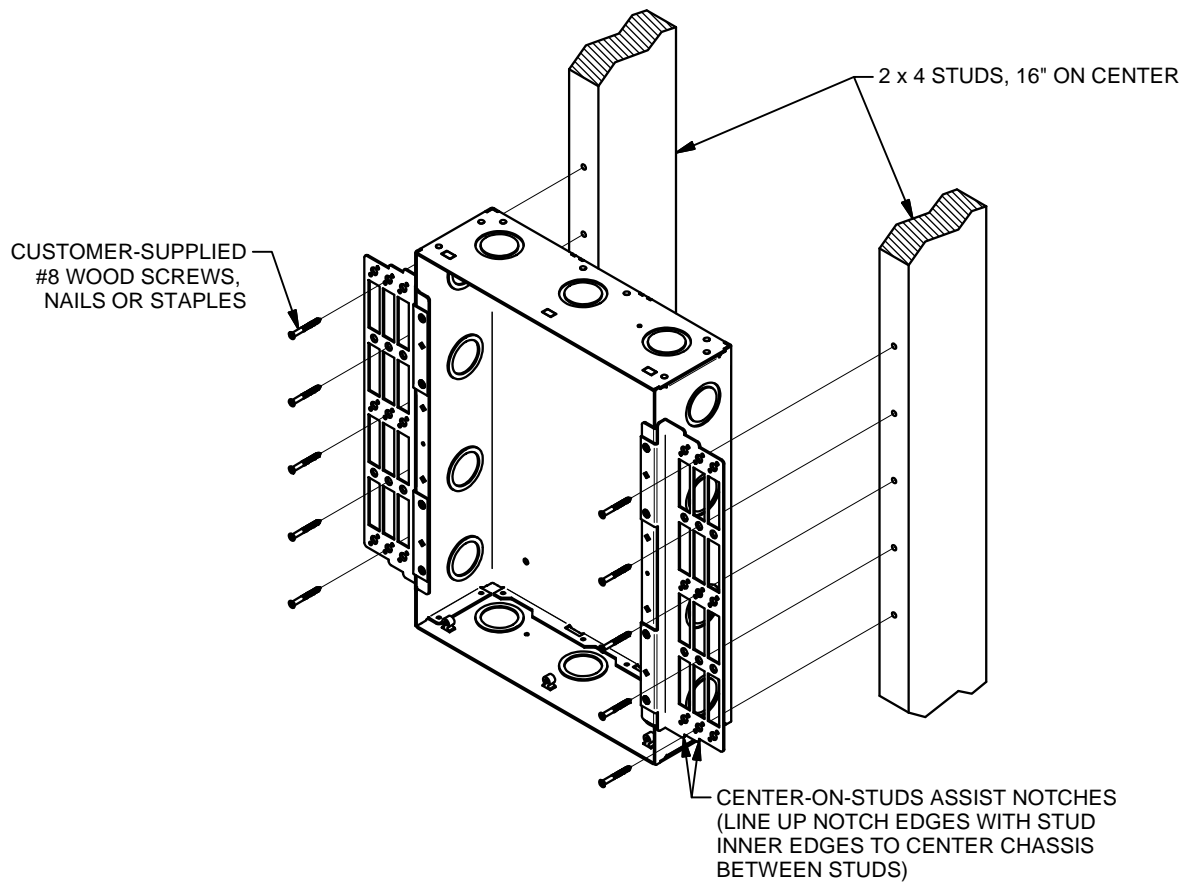

FIGURE 16