

## REGULATORY COMPLIANCE

FSR'S ELECTRONIC PRODUCTS have been tested for compliance with: FCC Class A and CE The Power Adapter has been tested for compliance with: UL, CSA and CE.

## WARRANTY POLICY

This product is warranted against failures due to defective parts or faulty workmanship for a period of one year after delivery to the original owner. During this period, FSR will make any necessary repairs or replace the unit without charge for parts or labor. Shipping charges to the factory or repair station must be prepaid by the owner, return-shipping charges, via UPS / FedEx ground, will be paid by FSR.

This warranty applies only to the original owner and is not transferable. In addition, it does not apply to repairs done by other than the FSR factory or Authorized Repair Stations.

This warranty shall be cancelable by FSR at its sole discretion if the unit has been subjected to physical abuse or has been modified in any way without written authorization from FSR. FSR's liability under this warranty is limited to repair or replacement of the defective unit.

FSR will not be responsible for incidental or consequential damages resulting from the use or misuse of its products. Some states do not allow the exclusion of incidental or consequential damages, so the above limitations may not apply to you. This warranty gives you specific legal rights, and you may also have other rights which vary from state to state.

Warranty claims should be accompanied by a copy of the original purchase invoice showing the purchase date (if a Warranty Registration Card was mailed in at the time of purchase, this is not necessary). Before returning any equipment for repair, please read the important information on service below.

## SERVICE

Before returning any equipment for repair, please be sure that it is adequately packed and cushioned against damage in shipment, and that it is insured. We suggest that you save the original packaging and use it to ship the product for servicing. Also, please enclose a note giving your name, address, phone number and a description of the problem.

**NOTE: all equipment being returned for repair must have a Return Authorization (RMA) Number. To get a RMA Number, please call the FSR Service Department (973-785-4347).**

**Please display your RMA Number prominently on the front of all packages.**

### Contact Information:

244 Bergen Boulevard,  
West Paterson, NJ 07424

Tel: (973) 785-4347 · Fax: (973) 785-4207

E-Mail: [sales@fsrinc.com](mailto:sales@fsrinc.com) · Web: <http://www.fsrinc.com>

issue date: 1-03

# FSR

## SN-4100A VGA SWITCHER

*FOUR BY ONE AUDIO/VIDEO SWITCHER*

## OPERATIONS MANUAL



244 Bergen Boulevard, West Paterson, NJ 07424

Tel: (973) 785-4347 · Fax: (973) 785-4207

E-Mail: [sales@fsrinc.com](mailto:sales@fsrinc.com)

Web: <http://www.fsrinc.com>

## PROPRIETARY INFORMATION

*All information in this manual is proprietary to and the property of FSR inc. This publication is protected by the Federal Copyright Law, with all rights reserved. No part of this document may be reproduced, transcribed, or transmitted, in any form or by any means, without prior explicit written permission from FSR inc.*

---

### Operators Safety Summary

*The general safety information in this summary is for operating personnel.*

**Do Not Remove Covers or Panels** There are no user-serviceable parts within the unit. Removal of the top cover will expose dangerous voltages. To avoid personal injury, do not remove the top cover. Do not operate the unit without the cover installed.

**Power Source** This product is intended to operate from a power source that will not apply more than 230 volts rms between the supply conductors or between both supply conductor and ground. A protective ground connection by way of grounding conductor in the power cord is essential for safe operation.

**Grounding the Product** This product is grounded through the grounding conductor of the power cord. To avoid electrical shock, plug the power cord into a properly wired receptacle before connecting to the product input or output terminals. A protective-ground connection by way of the grounding conductor in the power cord is essential for safe operation.

**Use the Proper Power Cord** Use only the power cord and connector specified for your product. Use only a power cord that is in good condition. Refer cord and connector changes to qualified service personnel.

**Use the Proper Fuse** To avoid fire hazard, use only the fuse having identical type, voltage rating, and current rating characteristics. Refer fuse replacement to qualified service personnel.

**Do Not Operate in Explosive Atmospheres** To avoid explosion, do not operate this product in an explosive atmosphere.

### SYNC INPUTS

Impedance: 470 ohms  
Type: TTL high noise immunity  
Level: 1.9 volt minimum

### SYNC OUTPUT

Impedance 75 Ohm  
Level: 5 volts into Hi-Z, 2.4 Volts into 75 ohm load  
Rise / Fall Time: 0.8 nS  
Propagation Delay: 17nS

### POWER REQUIREMENTS

9 volts @ 400 mA (AC or DC).  
A 9 VAC @ 1 AMP power adapter is included with two pin Molex disconnect.

### MOUNTING

Standard 19" Rack Mount Kit included

### DB-9 Control I/O Pinout

PIN	FUNCTION
1	SWITCH 1 INPUT
2	SWITCH 3 INPUT
3	LAMP 1 OUTPUT
4	LAMP 3 OUTPUT
5	GROUND
6	SWITCH 2 INPUT
7	SWITCH 4 INPUT
8	LAMP 2 OUTPUT
9	LAMP 4 OUTPUT

### VGA Connector 15 pin High Density "D" connector

Connector may be reversed depending on which side is viewed.

Pin No.	Function	Pin No.	Function	Pin No.	Function
1	Red Video	6	Red Ground	11	ID0 (Ground)
2	Green Video	7	Green Ground	12	ID1 (No Connect)
3	Blue Video	8	Blue Ground	13	Horizontal Sync
4	Reserved	9	No Connect	14	Vertical Sync
5	Ground	10	Ground	15	No Connect

## TECHNICAL SPECIFICATIONS

### AUDIO

Bandwidth: 20 Hz to 20 kHz (+/- 0.1dB)  
THD + Noise: 0.03% @ 20 kHz at rated Max Output S/N > 98 dB  
Noise floor: < 90 dBm  
Stereo separation: -85 dB @ 1kHz  
Gain 6dB

### AUDIO INPUTS

Number / type: 4 stereo balanced (may be used with unbalanced sources)  
Connectors: 5 Position pluggable screw terminal  
Impedance: 20Kohms balanced  
Max level: +6 dBm

### AUDIO OUTPUT

Number / type: 1 Balanced Stereo  
Connector: 5 Position pluggable screw terminal  
Impedance: 50 ohms  
Maximum Level: 600 ohms: +12 dBm Balanced / +6 dBm Unbalanced  
Hi - Z: +14 dBm Balanced / +8 dBm Unbalanced

### VIDEO INPUTS

Type: HD-15 Female (x4) standard VGA style  
Impedance: 75 ohms  
Level: 1 volt p-p nominal, +/-1.5 volt max  
VSWR: <1.2 @ 200 MHz typical  
Isolation: -40 dB @ 350 MHz typical off channel isolation

### VIDEO OUTPUT

Type: HD-15 Female (x1) standard VGA style  
Impedance: 75 ohms  
Gain: unity into 75 ohm load  
Offset: 15 mV max  
Bandwidth: 350 MHz  
Flatness: 0.25 dB to 250MHz  
VSWR: <1.2 @ 190 MHz

### CONTROL I/O

Type: "Hardwire" via contact closure and lamp feedback  
Connector: DB-9 Female (no RS-232 serial port)  
Switch input: Normally open momentary inputs  
Lamp Tally Output 5 VDC @ 15 MA. Current limited LED outputs (latched)

## FEATURES

- Affordable
- Ultra High Bandwidth
- Easy to Use
- With and Without Stereo Audio

## INTRODUCTION

The SN-4100 series switcher is a 4 input to 1 output high resolution VGA switcher. The 'A' models include balanced stereo audio switching with audio following video.

The SN-4100 is ideally suited for stand alone use or as an upstream switcher for a stand alone scaler such as the FSR MAS-3100 or a scaling switcher such as the FSR Compass, Compass S2 or Omni Navigator. The SN-4100 could also be used to route 4 high resolution signals to a down converter such as the FSR MDC-MK1.

At 1 RU in height, and 1/2 rack wide, the SN-4100 is easy to install and does not require an excessive amount of space. All connections are on the back of the unit using HD-15's for VGA and 5 position plug-gable Phoenix connectors for stereo balanced audio.

Control of the SN-4100 is available on the front panel through 4, large, easy to see push buttons with an LED that illuminates for the selected input. The SN-4100 also provides a contact closure interface, with lamp feedback, for remote control or to interface to an AMX or Crestron system.

As with all FSR products, the SN-4100 includes all of the necessary accessories for use and installation. The SN-4100 ships with a power supply, manual and a full width rack mount kit with removable blank.

## APPLICATIONS

- Classrooms
- Boardrooms
- Houses of Worship
- Rental and Staging

# INSTALLATION

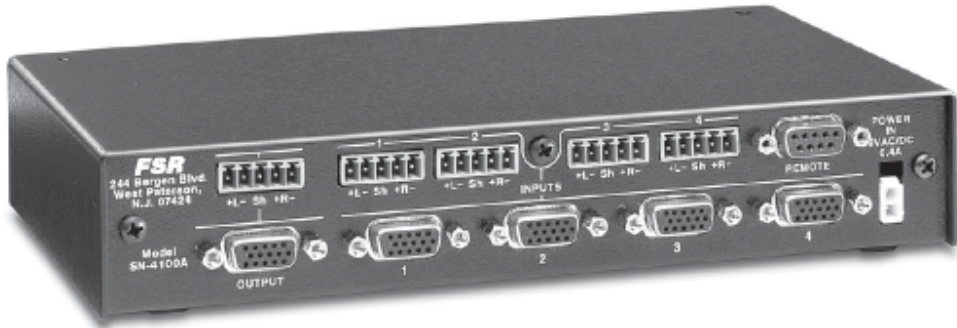

Connect each of the video sources to video inputs 1 through 4.

Connect each of the audio sources to audio inputs 1 through 4. (See diagrams)  
Use the diagrams on the following page for “mono” or unbalanced audio sources.

Connect the input from a control source to the remote input. (If used) Use the chart on the following page for the remote control pinout.

Connect the supplied AC adapter and plug it into a 117 VAC wall outlet. The input #1 LED should be lit on power up.

Connect the display device to SN-4100A video output connector.

Connect the SN-4100A audio output to the audio amplifier input and turn on the amplifier. (see pinout)

The input #1 image should now appear on the display and #1 audio input heard through the speakers. Adjust the amplifier for desired audio level

Depressing any of the other input select pushbuttons will display the respective audio and video input. Adjust each audio source gain controls for desired audio levels.

Shorting any of the four switch inputs on the DB-9 to pin 5 (ground) will also switch to that audio and video input. (See pinout)

There is a latching lamp tally output available on the DB-9 connector that follows the input status leds on the front panel pushbuttons and can be used to activate external indicators. (See pinout for details)

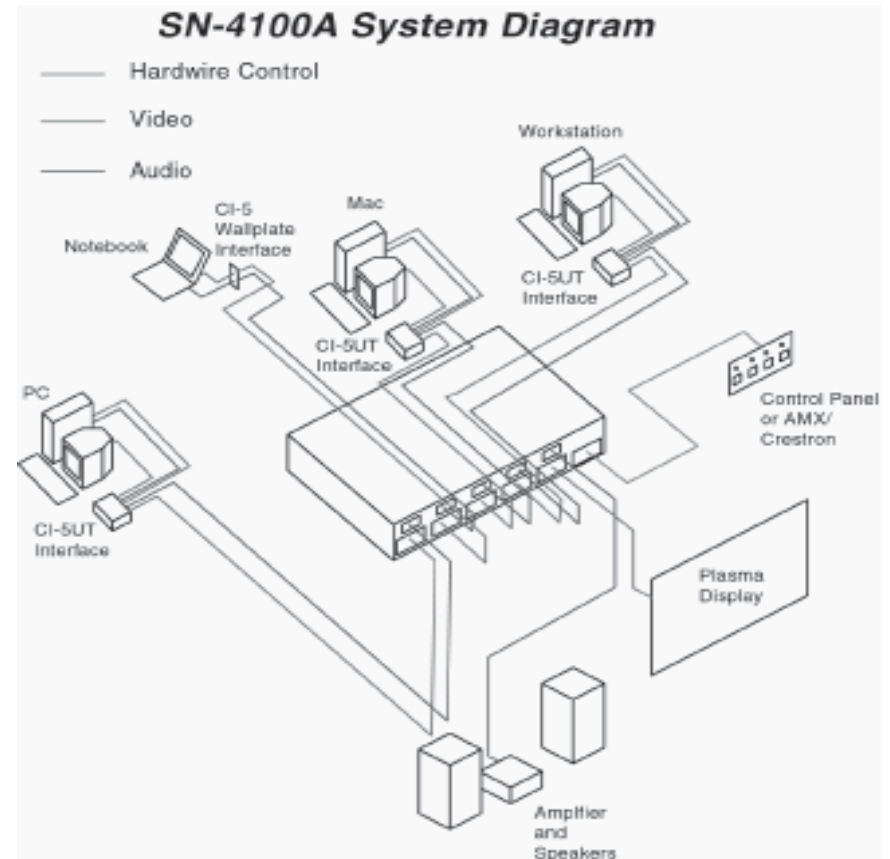

## Input Connector Wiring

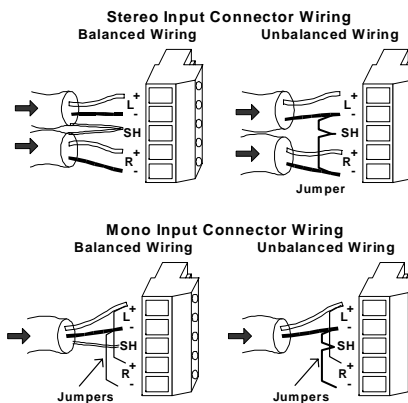

## Mic Input Connector Wiring

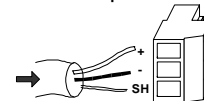

## Output Connector Wiring

