

3

2

1

(4) #6-32 x .250 LONG SCREW
(SUPPLIED WITH SF-(X)T-CV
AND SF-(X)C-CV)

TILE FLANGE FSR MODEL# SF-(X)T-CV
OR CARPET FLANGE (SHOWN BELOW)
FSR MODEL# SF-(X)C-CV

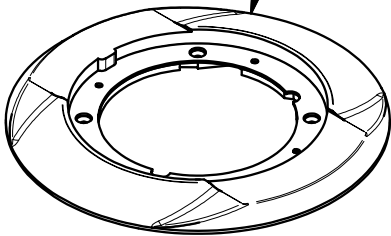

(SHOWN REDUCED IN SCALE)

FSR MODEL# SF-PK1

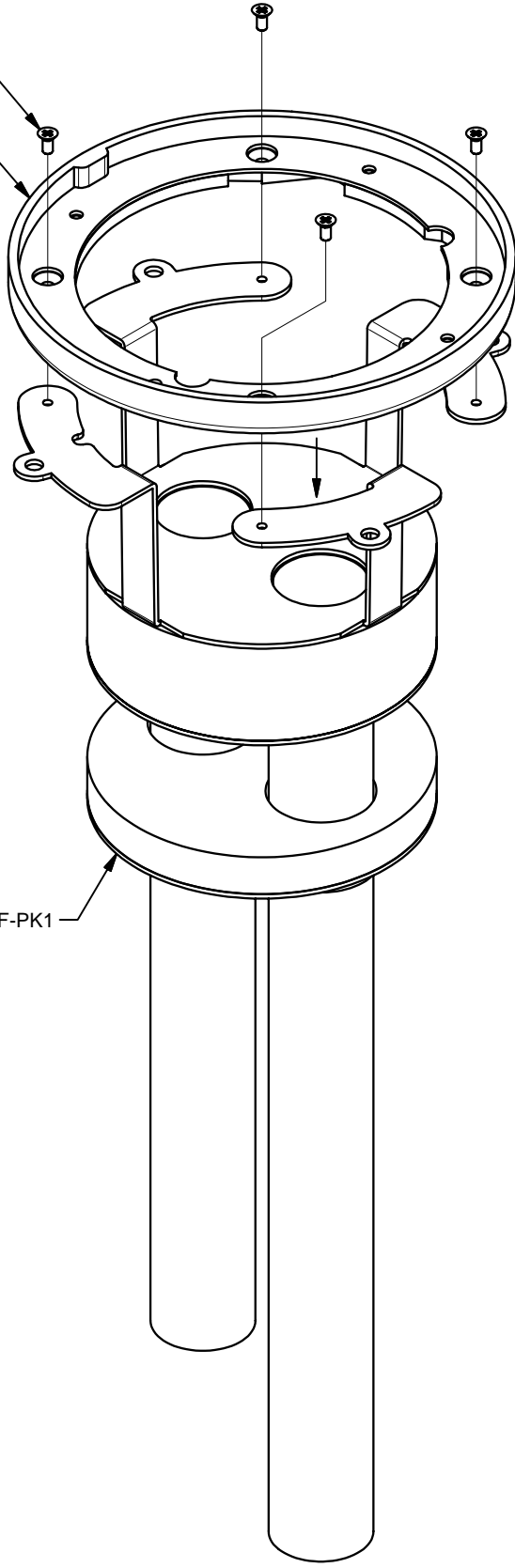

STEP 1 - POKE-THRU

FSR inc.
244 BERGEN BLVD.
W. PATERSON, NJ 07424
TEL (973) 785-4347
FAX (973) 785-3318

TITLE: SMART FIT COVER
FLANGE-TO-POKE THRU
ASSEMBLY INSTRUCTIONS
DRAWN BY: JRE DATE: 11/03/08 REV: 02
DWG#: C-1042A PAGE: 1 OF 3 SCALE: 1:2

3

2

1

3

2

1

D

D

C

C

B

B

A

A

(6) 4-40 x .375 LONG PHILLIPS PAN HEAD SCREW (SUPPLIED - DISCARD HARDWARE INCLUDED WITH IPS INSERTS)

IPS INSERT

FSR MODEL# SF-IPSP

(6) 4-40 KEP NUT (SUPPLIED)

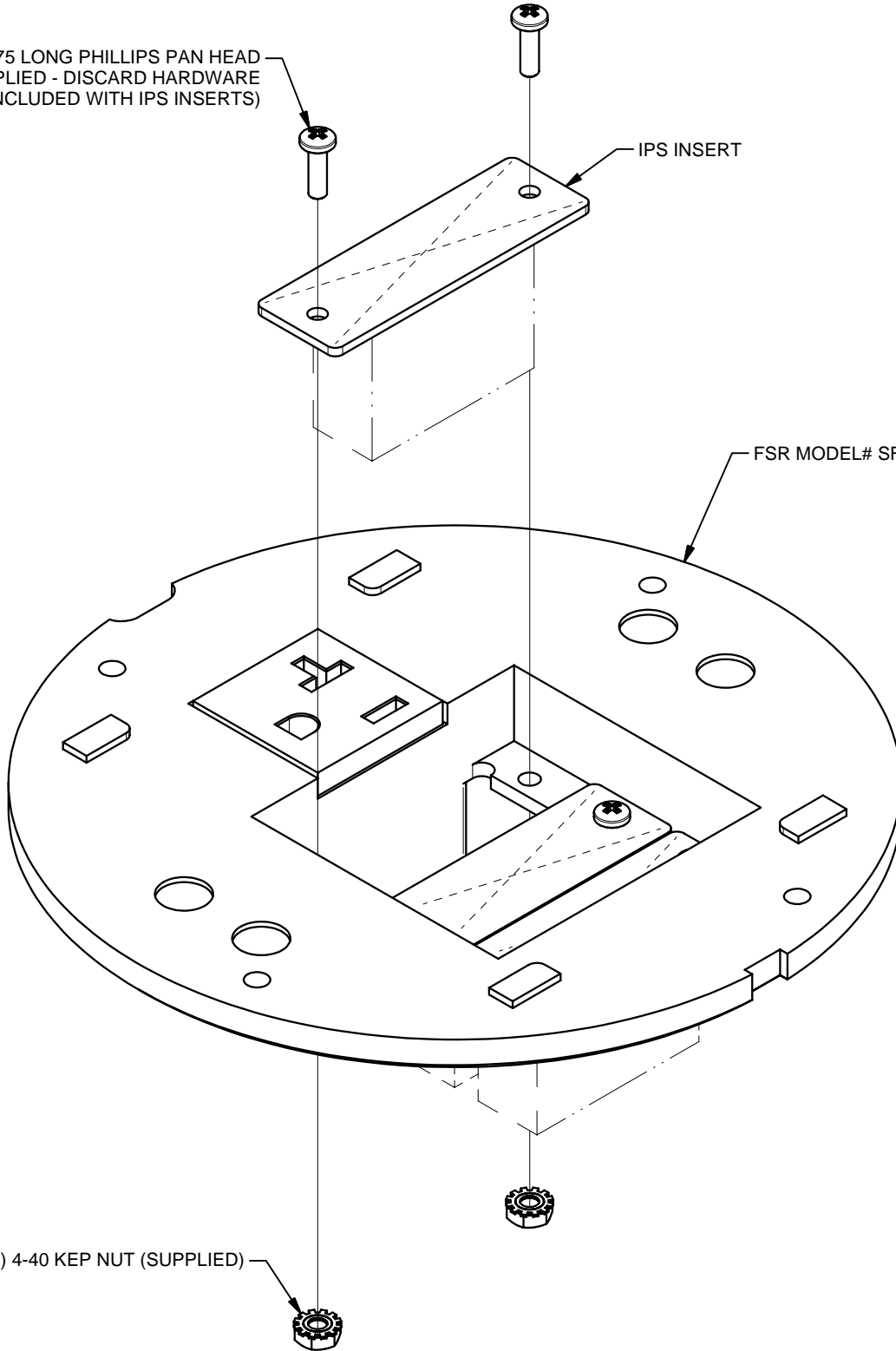

STEP 2 - POKE-THRU

FSR Inc.
 244 BERGEN BLVD.
 W. PATERSON, NJ 07424
 TEL (973) 785-4347
 FAX (973) 785-3318

TITLE: SMART FIT SF-IPSP
 ASSEMBLY INSTRUCTIONS
 DRAWN BY: JRE DATE: 11/03/08 REV: 02
 DWG#: C-1042A PAGE: 2 OF 3 SCALE: 1:1

3

2

1

D

D

C

C

B

B

A

A

(4) #6-32 x .625 LONG SCREW (SUPPLIED WITH SF-(X)T-CV AND SF-(X)C-CV)

COVER (SUPPLIED WITH SF-(X)T-CV AND SF-(X)C-CV)

FSR MODEL# SF-IPSP (ASSEMBLED WITH COMPONENTS)

AC DIVIDER (SUPPLIED WITH SF-IPSP)

TILE FLANGE FSR MODEL# SF-(X)T-CV OR CARPET FLANGE (SHOWN BELOW) FSR MODEL# SF-(X)C-CV

(SHOWN REDUCED IN SCALE)

FSR MODEL# SF-PK1

STEP 3 - POKE-THRU

FSR Inc.
244 BERGEN BLVD.
W. PATERSON, NJ 07424
TEL (973) 785-4347
FAX (973) 785-3318

TITLE: SMART FIT SF-IPSP
ASSEMBLY INSTRUCTIONS
DRAWN BY: JRE DATE: 11/03/08 REV: 02
DWG#: C-1042A PAGE: 3 OF 3 SCALE: 1:3

(4) #6-32 x .250 LONG SCREW
(SUPPLIED WITH SF-(X)T-CV
AND SF-(X)C-CV)

TILE FLANGE FSR MODEL# SF-(X)T-CV
OR CARPET FLANGE (SHOWN BELOW)
FSR MODEL# SF-(X)C-CV

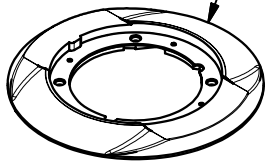

(SHOWN REDUCED IN SCALE)

(3) BARBED CLIP
(SUPPLIED WITH SF-PB)

BARBED CLIP WITH GROUND
LUG (SUPPLIED WITH SF-PD)

AC DIVIDER
(SUPPLIED
WITH SF-IPSP)

FSR MODEL# SF-PB

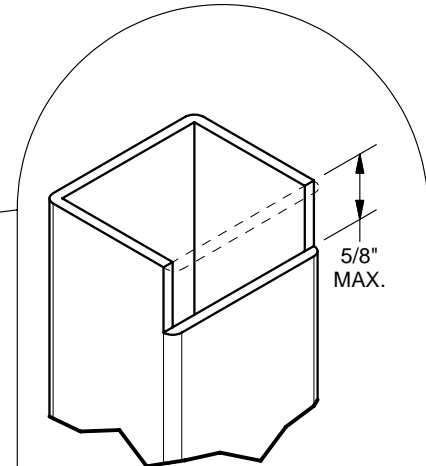

5/8"
MAX.

AC DIVIDER TUBE MAY NEED
MODIFICATION, AS SHOWN
ABOVE, TO ALLOW CLEARANCE
FOR ANY IPS INSERTS WHICH,
BENEATH THEIR FACE PANEL,
ARE AS WIDE AS THE FACE PANEL
OR NEARLY SO (E.G., IPS-C612S,
IPS-V310S, IPS-D710S THRU
IPS-D714S), AND PLACED
IN THE -IPSP POSITION NEAREST
THE A/C OUTLET. PRIOR TO POUR
BOX INSTALLATION, VERIFY IF
THIS MODIFICATION IS REQUIRED
BY EITHER PERUSAL OF INTENDED
INSERTS OR BY TEST FITTING
ASSEMBLY OF ALL COMPONENTS.

STEP 1 - POUR BOX

FSR Inc.
244 BERGEN BLVD.
W. PATERSON, NJ 07424
TEL (973) 785-4347
FAX (973) 785-3318

TITLE: SMART FIT COVER
FLANGE-TO-POKE POUR BOX
ASSEMBLY INSTRUCTIONS
DRAWN BY: JRE DATE: 11/03/08 REV: 02
DWG#: C-1042B PAGE: 1 OF 3 SCALE: 1:3

3

2

1

D

D

C

C

B

B

A

A

(6) 4-40 x .375 LONG PHILLIPS PAN HEAD SCREW (SUPPLIED - DISCARD HARDWARE INCLUDED WITH IPS INSERTS)

IPS INSERT

FSR MODEL# SF-IPSP

(6) 4-40 KEP NUT (SUPPLIED)

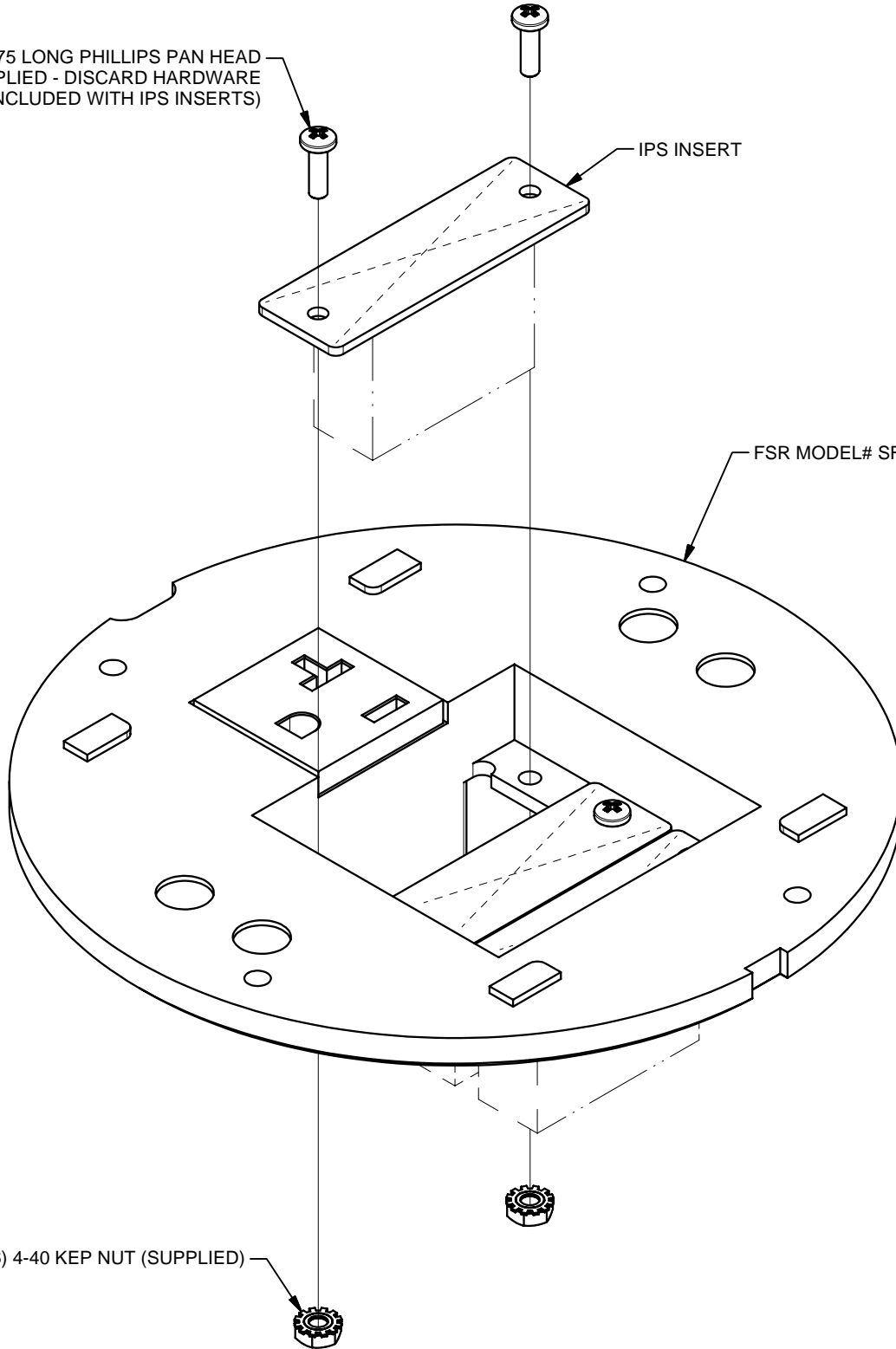

STEP 2 - POUR BOX

FSR Inc.
 244 BERGEN BLVD.
 W. PATERSON, NJ 07424
 TEL (973) 785-4347
 FAX (973) 785-3318

TITLE: SMART FIT SF-IPSP
 ASSEMBLY INSTRUCTIONS
 DRAWN BY: JRE DATE: 11/03/08 REV: 02
 DWG#: C-1042B PAGE: 2 OF 3 SCALE: 1:1

3

2

1

D

D

C

C

B

B

A

A

(4) #6-32 x .625 LONG SCREW (SUPPLIED WITH SF-(X)T-CV AND SF-(X)C-CV)

COVER (SUPPLIED WITH SF-(X)T-CV AND SF-(X)C-CV)

FSR MODEL# SF-IPSP (ASSEMBLED WITH COMPONENTS)

TILE FLANGE FSR MODEL# SF-(X)T-CV OR CARPET FLANGE (SHOWN BELOW) FSR MODEL# SF-(X)C-CV

(SHOWN REDUCED IN SCALE)

FSR MODEL# SF-PB

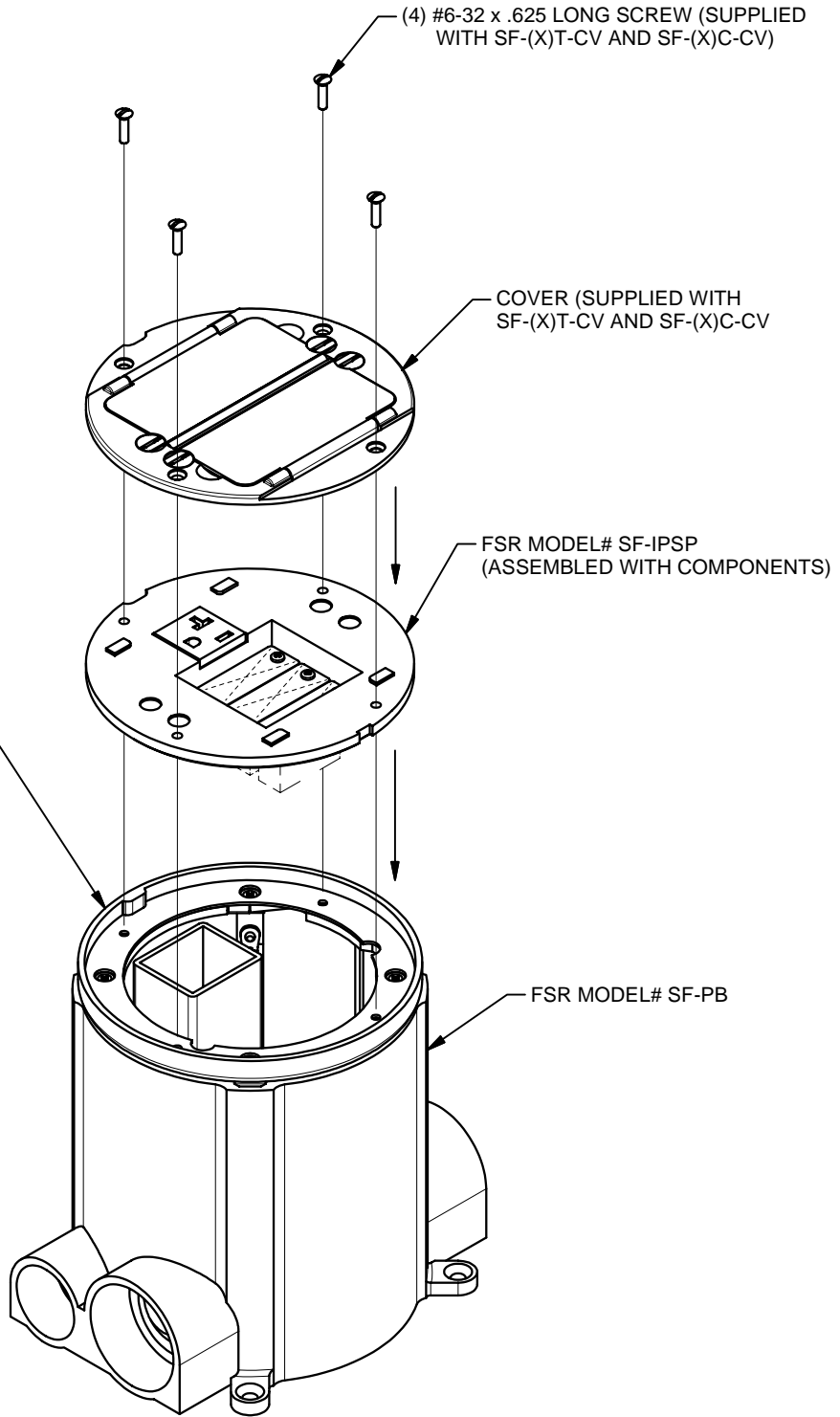

STEP 3 - POUR BOX

FSR Inc.
 244 BERGEN BLVD.
 W. PATERSON, NJ 07424
 TEL (973) 785-4347
 FAX (973) 785-3318

TITLE: SMART FIT SF-IPSP
 ASSEMBLY INSTRUCTIONS
 DRAWN BY: JRE DATE: 11/03/08 REV: 02
 DWG#: C-1042B PAGE: 3 OF 3 SCALE: 1:3