

STEP 1 - POKE-THRU

FSR inc.
244 BERGEN BLVD.
W. PATERSON, NJ 07424
TEL (973) 785-4347
FAX (973) 785-3318

TITLE: SMART FIT COVER
FLANGE-TO-POKE THRU
ASSEMBLY INSTRUCTIONS

DRAWN BY: JRE	DATE: 11/03/08	REV: 03
DWG#: C-1035A	PAGE: 1 OF 4	SCALE: 1:2

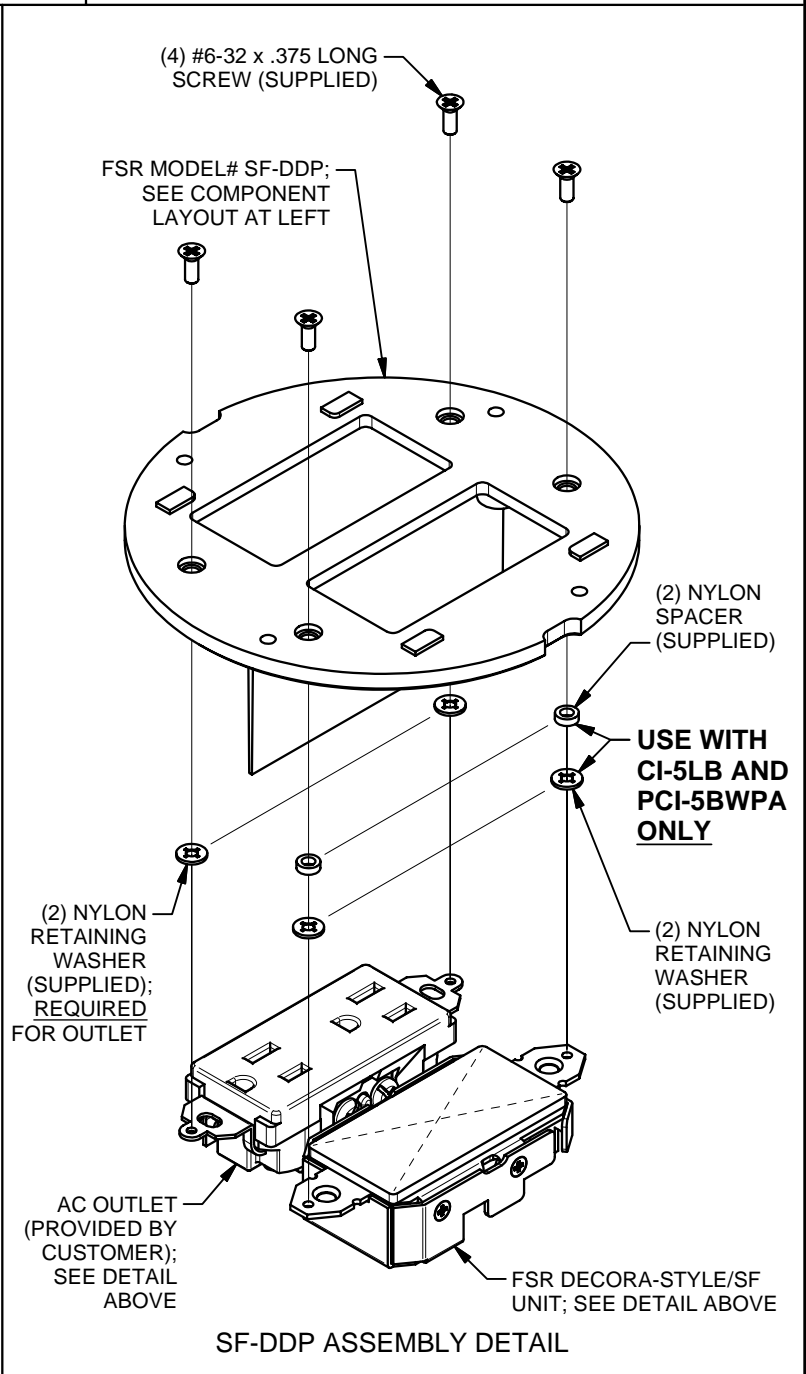
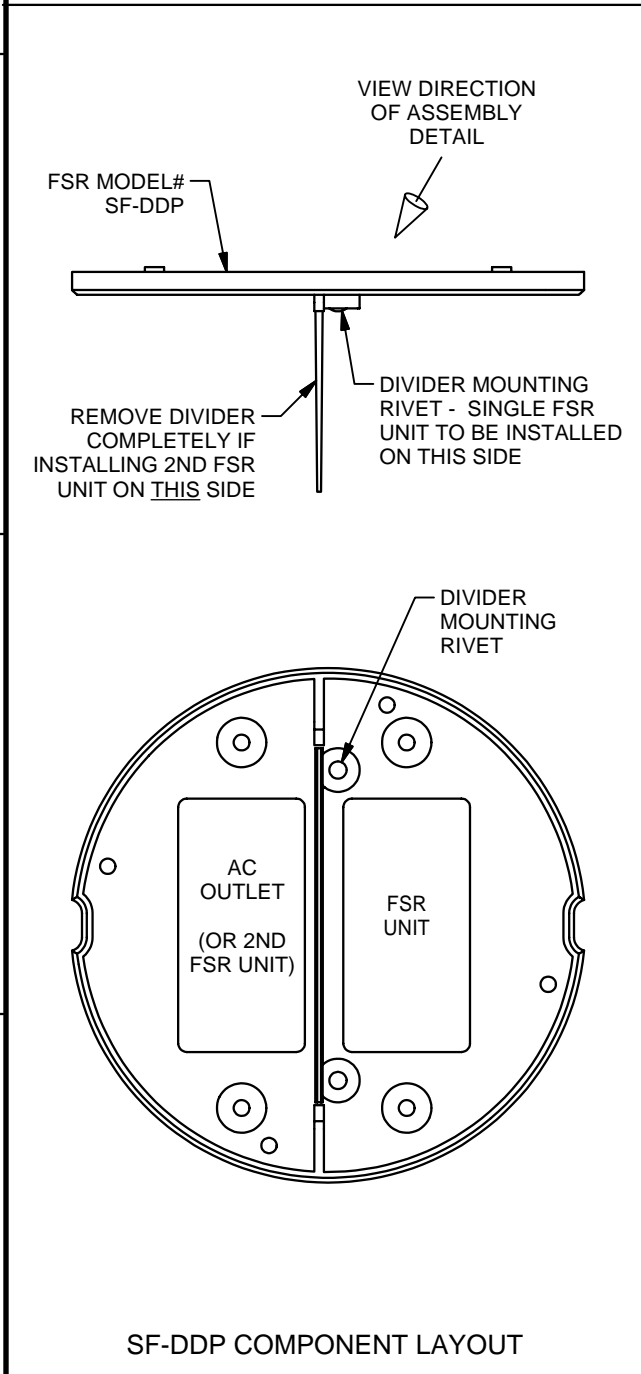
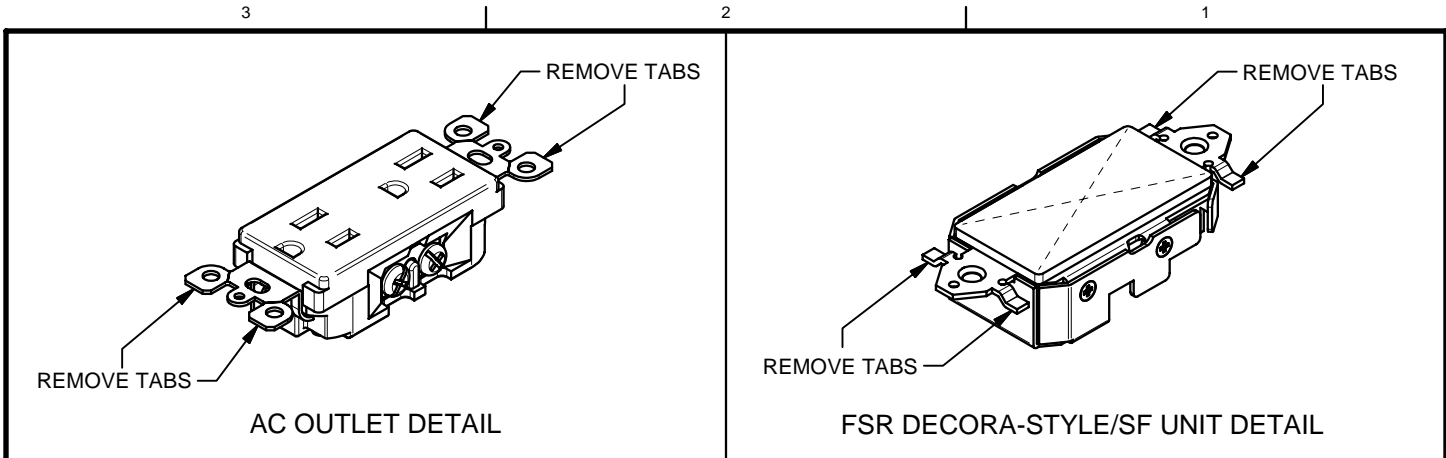

STEP 2a - POKE-THRU

FSR Inc.
 244 BERGEN BLVD.
 W. PATERSON, NJ 07424
 TEL (973) 785-4347
 FAX (973) 785-3318

TITLE: SMART FIT SF-DDP ASSEMBLY INSTRUCTIONS
 DRAWN BY: JRE DATE: 11/03/08 REV: 03
 DWG#: C-1035A PAGE: 2 OF 4 SCALE: 1:2

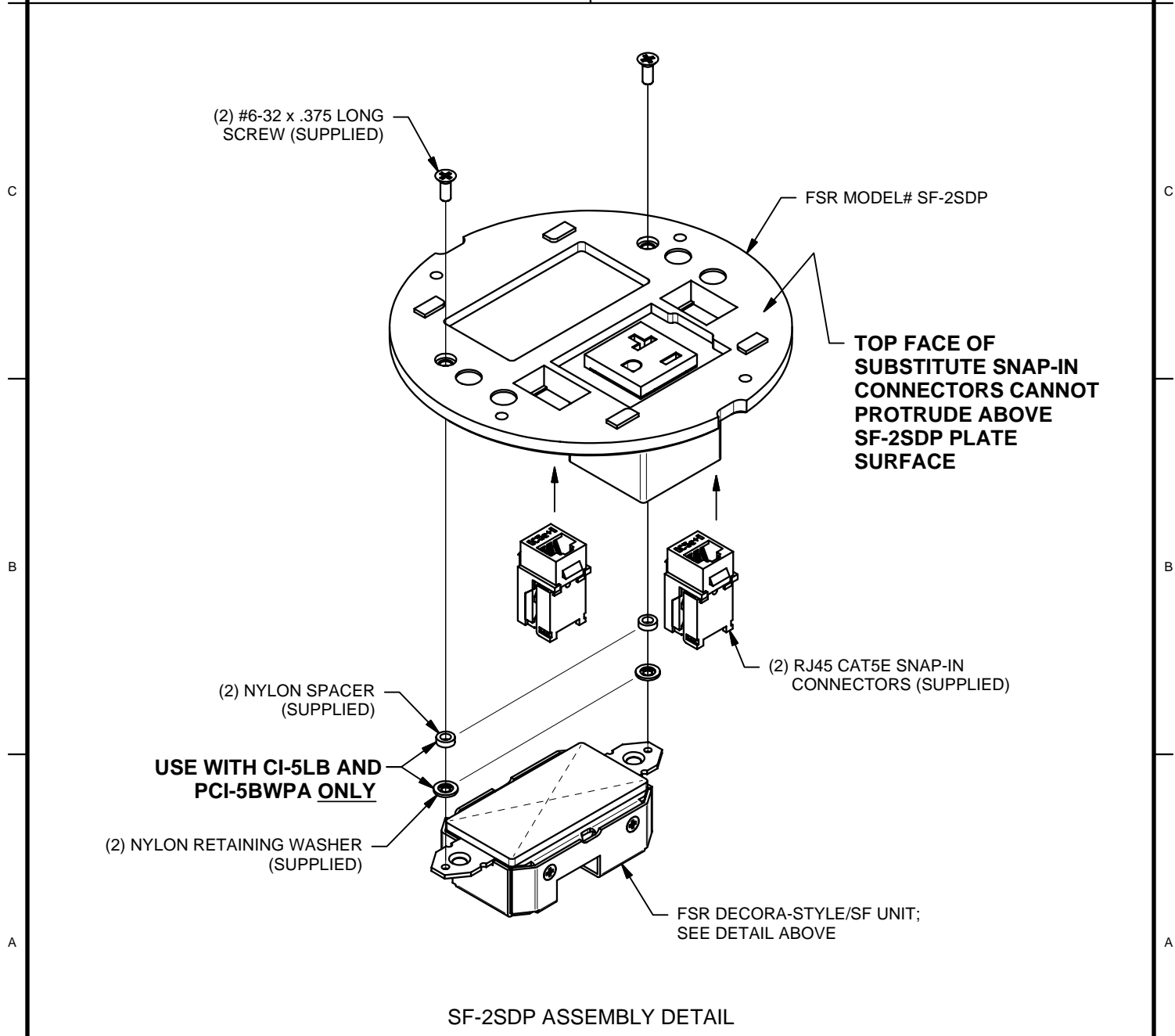
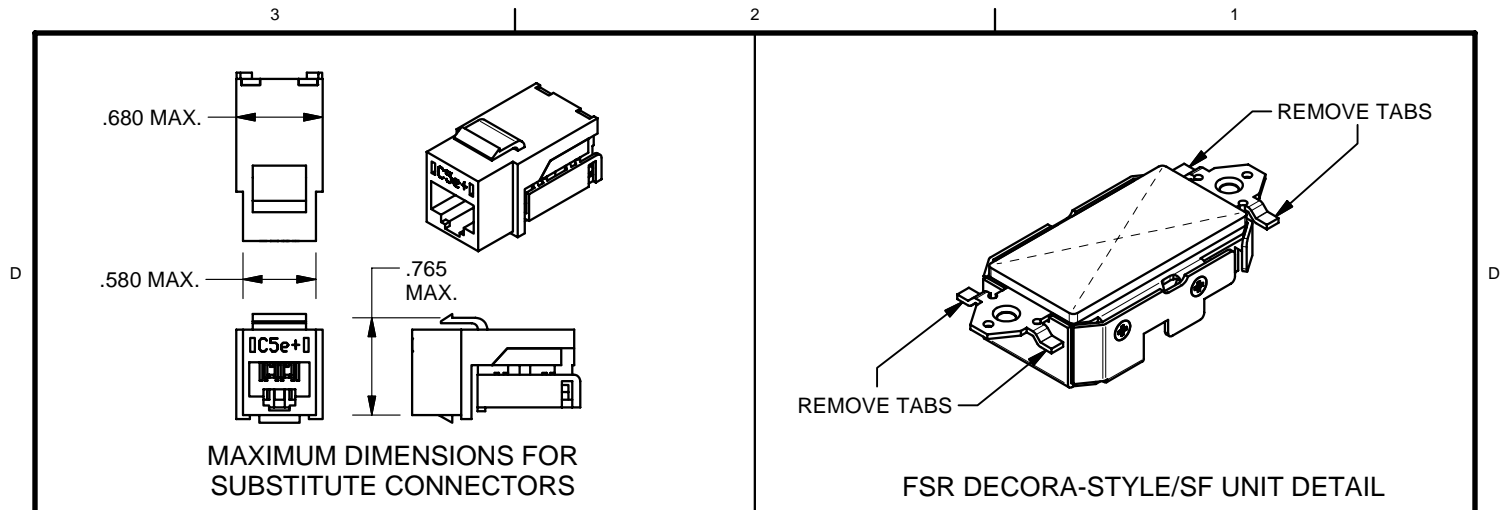

STEP 2b - POKE-THRU

FSR Inc.
 244 BERGEN BLVD.
 W. PATERSON, NJ 07424
 TEL (973) 785-4347
 FAX (973) 785-3318

TITLE: SMART FIT SF-2SDP ASSEMBLY INSTRUCTIONS
 DRAWN BY: JRE DATE: 11/03/08 REV: 03
 DWG#: C-1035A PAGE: 3 OF 4 SCALE: 1:2

D

D

C

C

B

B

A

A

(4) #6-32 x .625 LONG SCREW (SUPPLIED WITH SF-(X)T-CV AND SF-(X)C-CV)

COVER (SUPPLIED WITH SF-(X)T-CV AND SF-(X)C-CV)

FSR MODEL# SF-DDP or SF-2SDP (ASSEMBLED WITH COMPONENTS) (SF-2SDP SHOWN)

AC DIVIDER (SUPPLIED WITH SF-2SDP) TO BE USED WITH SF-2SDP ONLY

TILE FLANGE FSR MODEL# SF-(X)T-CV OR CARPET FLANGE (SHOWN BELOW) FSR MODEL# SF-(X)C-CV

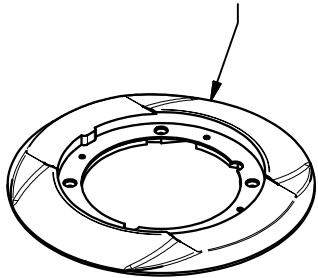

(SHOWN REDUCED IN SCALE)

FSR MODEL# SF-PK1

STEP 3 - POKE-THRU

FSR Inc.
244 BERGEN BLVD.
W. PATERSON, NJ 07424
TEL (973) 785-4347
FAX (973) 785-3318

TITLE: SMART FIT SF-DDP/2SDP ASSEMBLY INSTRUCTIONS
DRAWN BY: JRE DATE: 11/03/08 REV: 03
DWG#: C-1035A PAGE: 4 OF 4 SCALE: 1:3

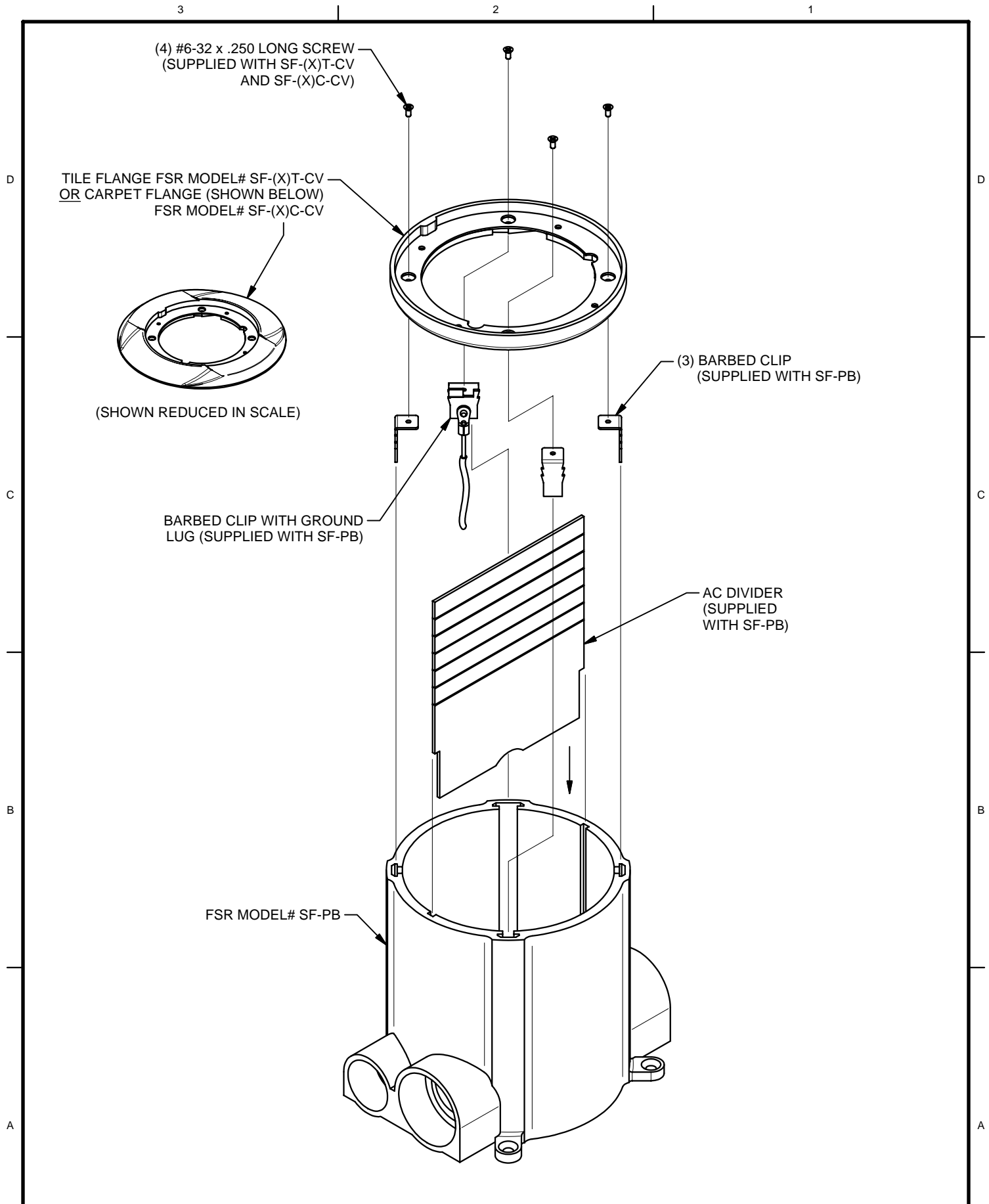

STEP 1 - POUR BOX

FSR Inc.
244 BERGEN BLVD.
W. PATERSON, NJ 07424
TEL (973) 785-4347
FAX (973) 785-3318

TITLE: SMART FIT COVER
FLANGE-TO-POKE POUR BOX
ASSEMBLY INSTRUCTIONS

DRAWN BY: JRE	DATE: 11/03/08	REV: 03
DWG#: C-1035B	PAGE: 1 OF 3	SCALE: 1:3

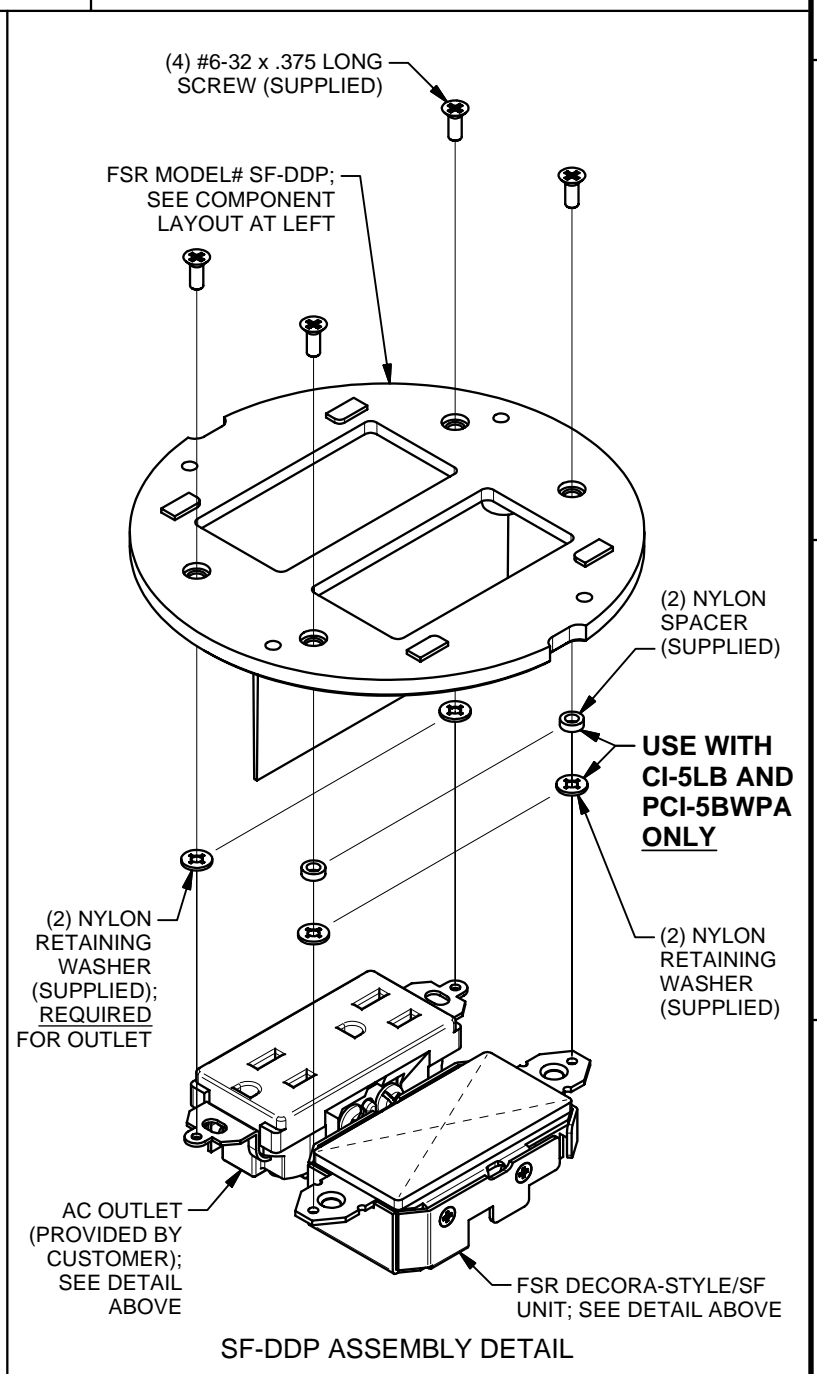
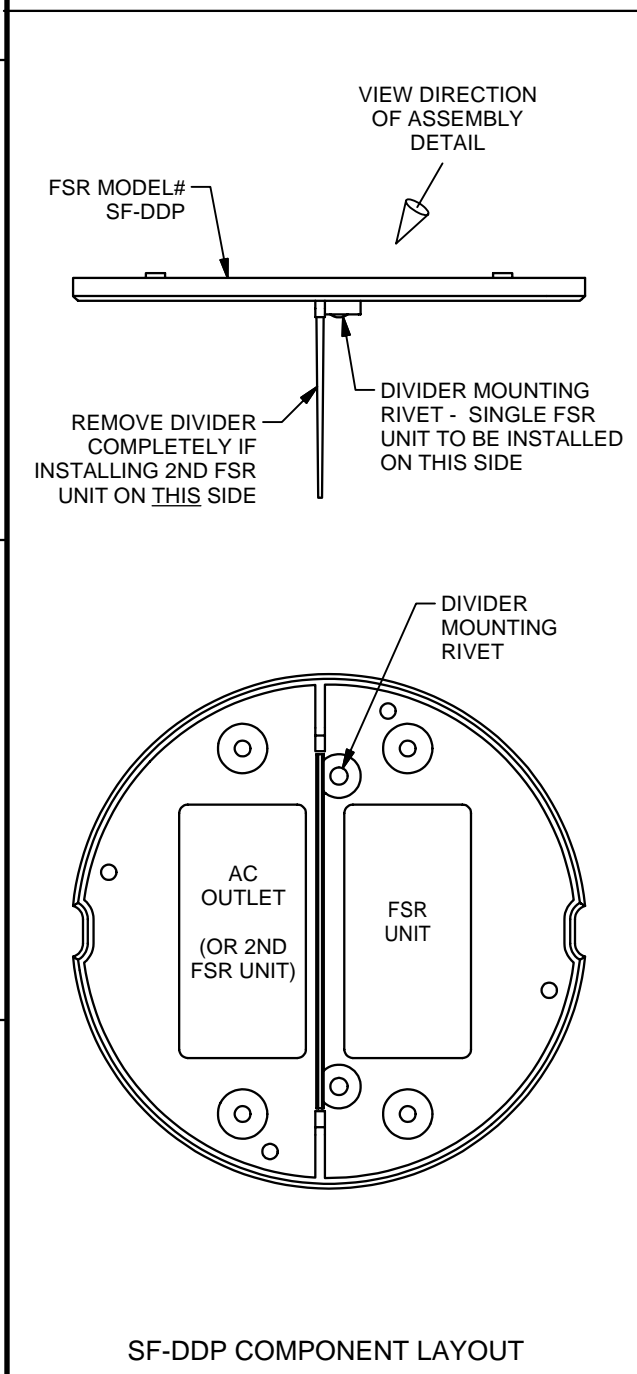
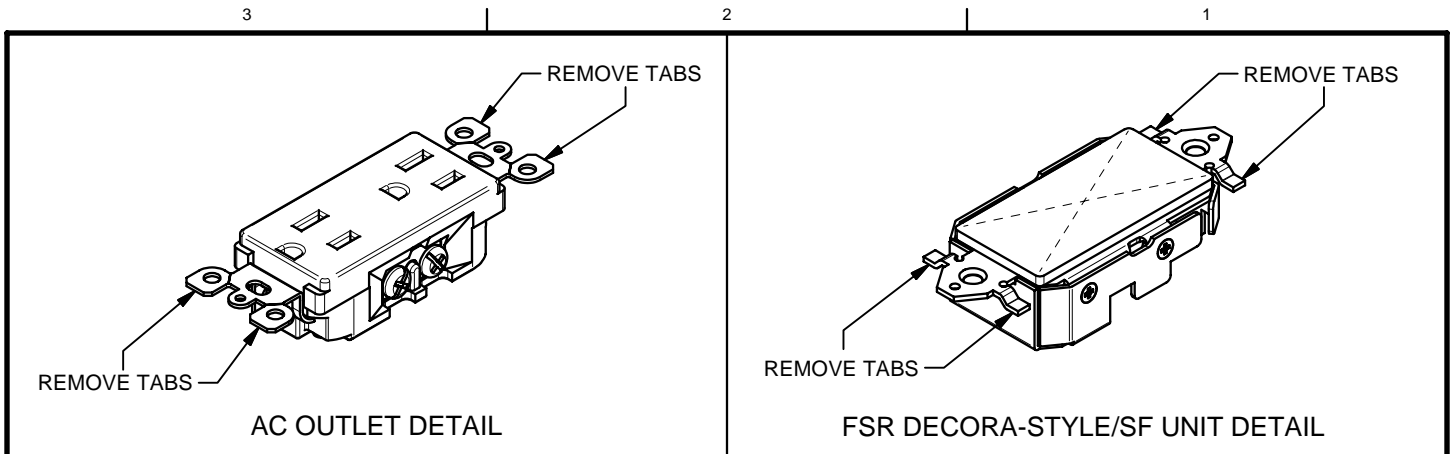

STEP 2 - POUR BOX

FSR Inc.
 244 BERGEN BLVD.
 W. PATERSON, NJ 07424
 TEL (973) 785-4347
 FAX (973) 785-3318

TITLE: SMART FIT SF-DDP ASSEMBLY INSTRUCTIONS
 DRAWN BY: JRE DATE: 11/03/08 REV: 03
 DWG#: C-1035B PAGE: 2 OF 3 SCALE: 1:2

D

D

C

C

B

B

A

A

(4) #6-32 x .625 LONG SCREW (SUPPLIED WITH SF-(X)T-CV AND SF-(X)C-CV)

COVER (SUPPLIED WITH SF-(X)T-CV AND SF-(X)C-CV)

FSR MODEL# SF-DDP (ASSEMBLED WITH COMPONENTS)

TILE FLANGE FSR MODEL# SF-(X)T-CV OR CARPET FLANGE (SHOWN BELOW) FSR MODEL# SF-(X)C-CV

FSR MODEL# SF-PB

(SHOWN REDUCED IN SCALE)

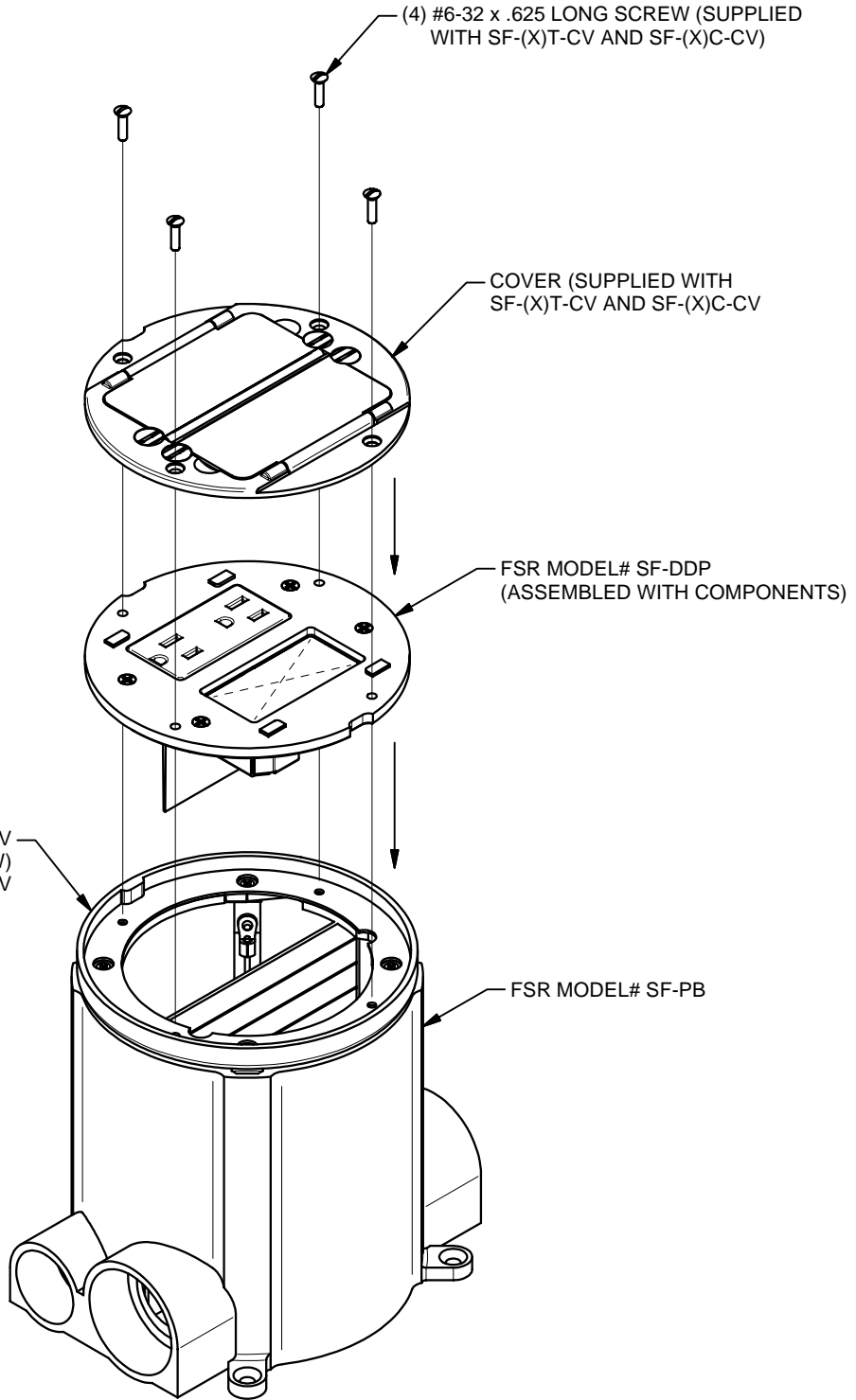

STEP 3 - POUR BOX

FSR Inc.
 244 BERGEN BLVD.
 W. PATERSON, NJ 07424
 TEL (973) 785-4347
 FAX (973) 785-3318

TITLE: SMART FIT SF-DDP ASSEMBLY INSTRUCTIONS
 DRAWN BY: JRE DATE: 11/03/08 REV: 03
 DWG#: C-1035B PAGE: 3 OF 3 SCALE: 1:3

(4) #6-32 x .250 LONG SCREW
(SUPPLIED WITH SF-(X)T-CV
AND SF-(X)C-CV)

TILE FLANGE FSR MODEL# SF-(X)T-CV
OR CARPET FLANGE (SHOWN BELOW)
FSR MODEL# SF-(X)C-CV

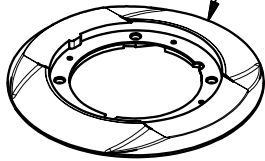

(SHOWN REDUCED IN SCALE)

(3) BARBED CLIP
(SUPPLIED WITH SF-PB)

BARBED CLIP WITH GROUND
LUG (SUPPLIED WITH SF-PD)

AC DIVIDER
(SUPPLIED
WITH SF-IPSP)

FSR MODEL# SF-PB

D
C
B
A

D
C
B
A

STEP 1 - POUR BOX

FSR inc.
244 BERGEN BLVD.
W. PATERSON, NJ 07424
TEL (973) 785-4347
FAX (973) 785-3318

TITLE: SMART FIT COVER FLANGE-TO-POKE POUR BOX ASSEMBLY INSTRUCTIONS			
DRAWN BY: JRE	DATE: 11/03/08	REV: 03	
DWG#: C-1035C	PAGE: 1 OF 3	SCALE: 1:3	

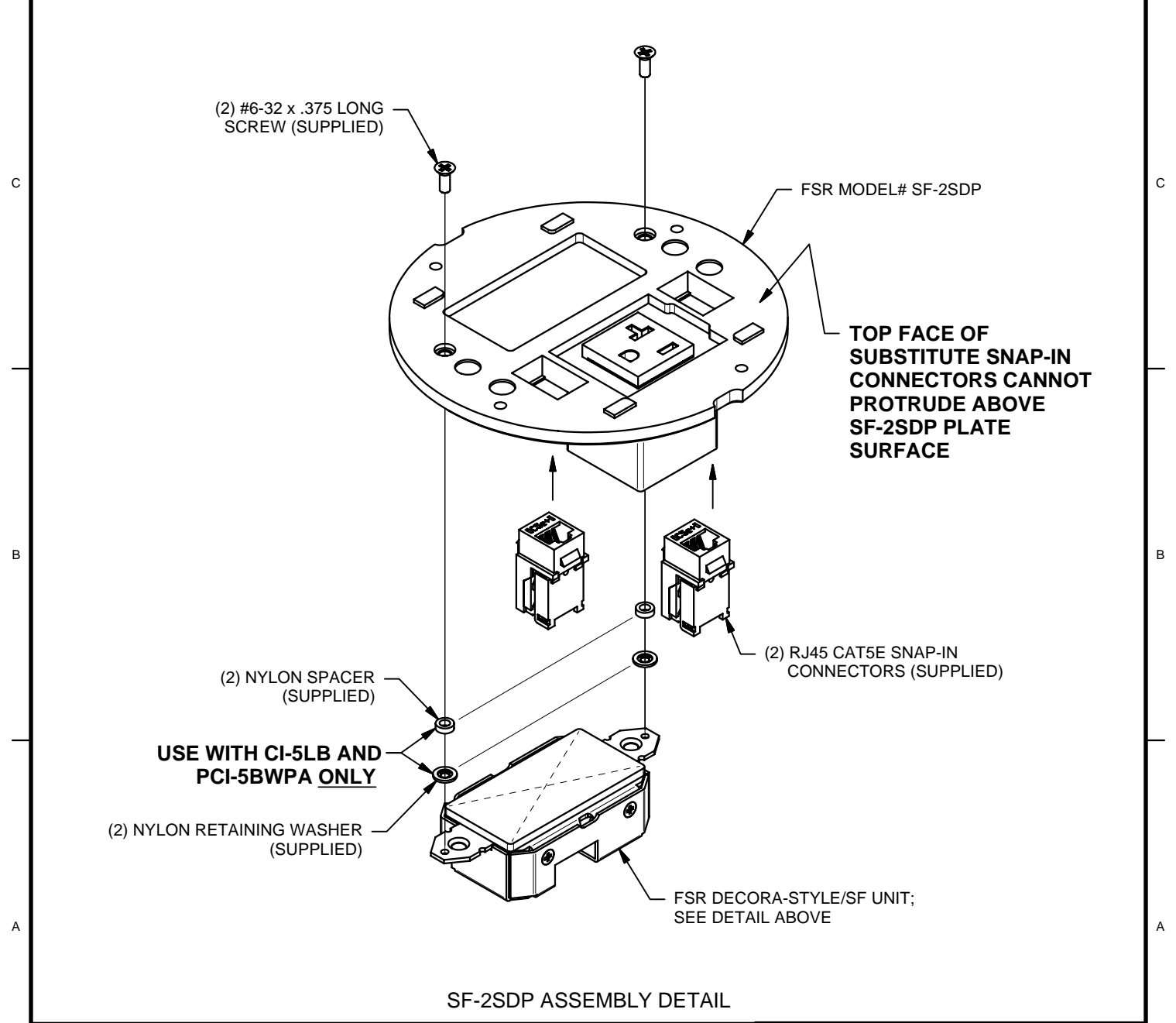
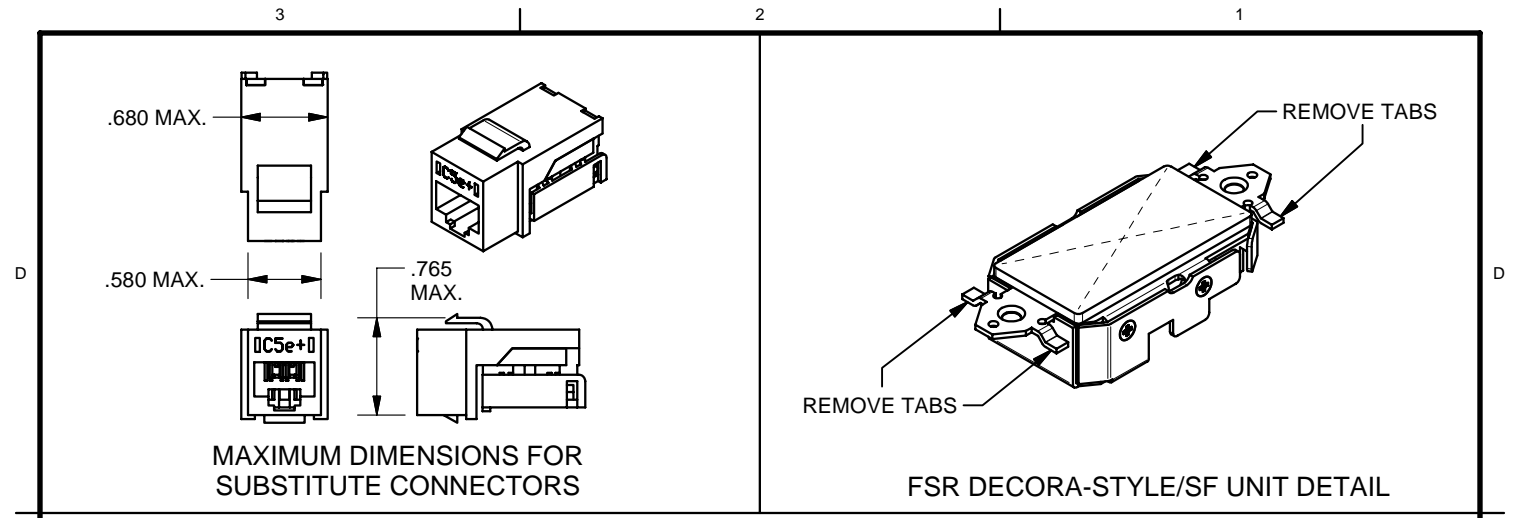

STEP 2 - POUR BOX

FSR Inc.
 244 BERGEN BLVD.
 W. PATERSON, NJ 07424
 TEL (973) 785-4347
 FAX (973) 785-3318

TITLE: SMART FIT SF-2SDP ASSEMBLY INSTRUCTIONS
 DRAWN BY: JRE DATE: 11/03/08 REV: 03
 DWG#: C-1035C PAGE: 2 OF 3 SCALE: 1:2

D

D

C

C

B

B

A

A

(4) #6-32 x .625 LONG SCREW (SUPPLIED WITH SF-(X)T-CV AND SF-(X)C-CV)

COVER (SUPPLIED WITH SF-(X)T-CV AND SF-(X)C-CV)

FSR MODEL# SF-2SDP (ASSEMBLED WITH COMPONENTS)

TILE FLANGE FSR MODEL# SF-(X)T-CV OR CARPET FLANGE (SHOWN BELOW) FSR MODEL# SF-(X)C-CV

FSR MODEL# SF-PB

(SHOWN REDUCED IN SCALE)

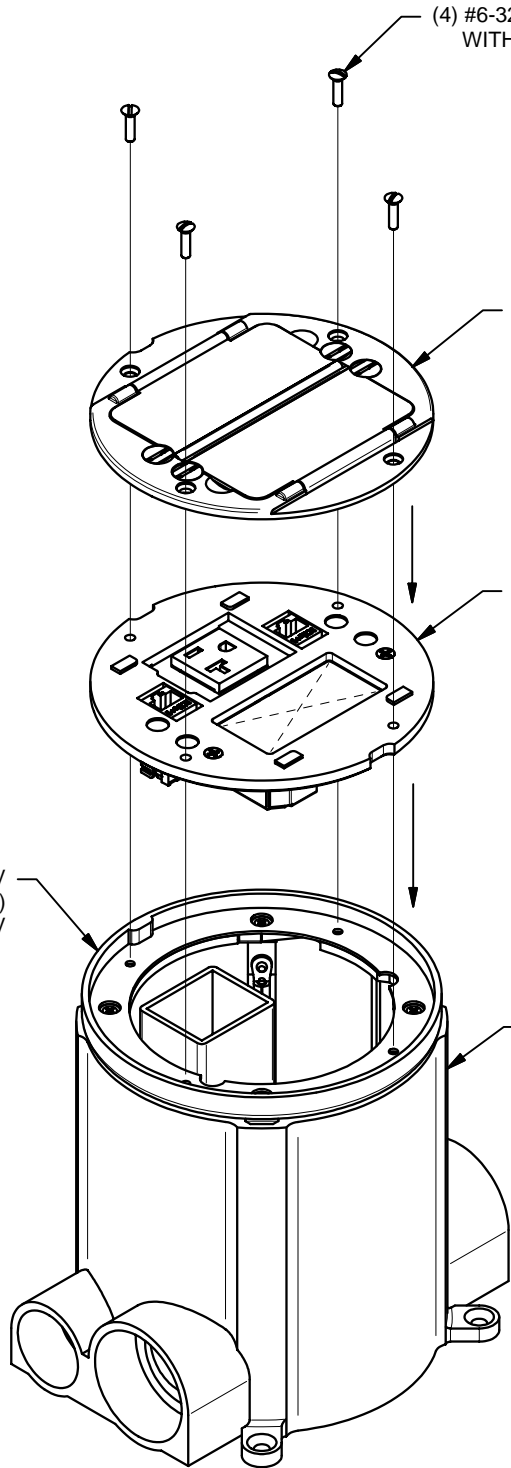

STEP 3 - POUR BOX

FSR Inc.
 244 BERGEN BLVD.
 W. PATERSON, NJ 07424
 TEL (973) 785-4347
 FAX (973) 785-3318

TITLE: SMART FIT SF-2SDP ASSEMBLY INSTRUCTIONS		
DRAWN BY: JRE	DATE: 11/03/08	REV: 03
DWG#: C-1035C	PAGE: 3 OF 3	SCALE: 1:3