

TYPICAL INSTALLATION USING THE FL-GRD2

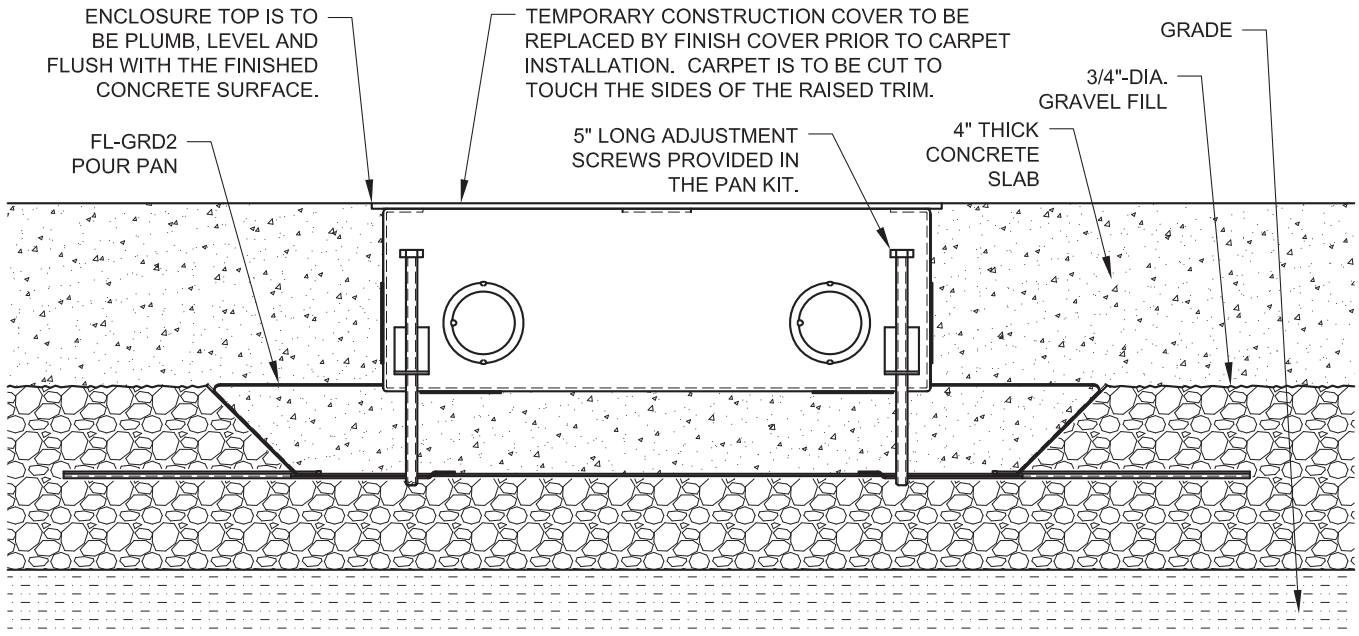

TYPICAL INSTALLATION USING THE FL-GRD4

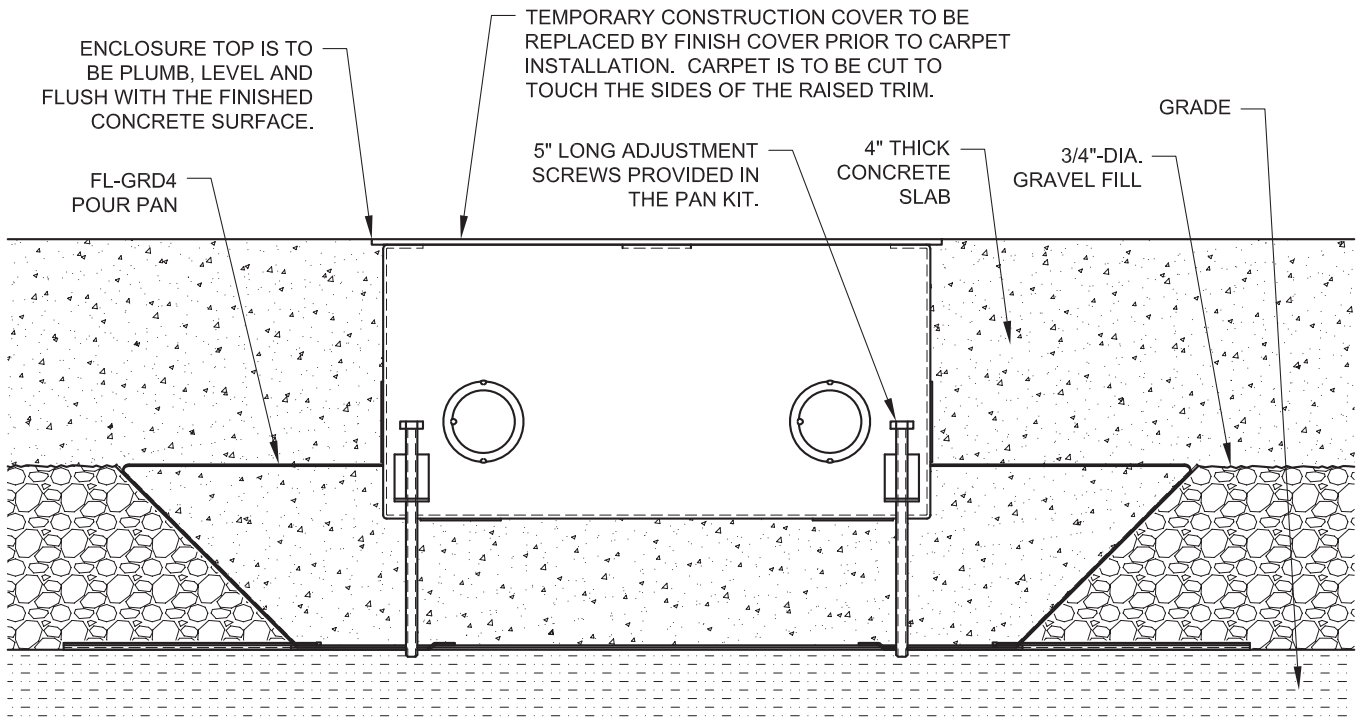

TYPICAL INSTALLATION USING THE FL-GRD200

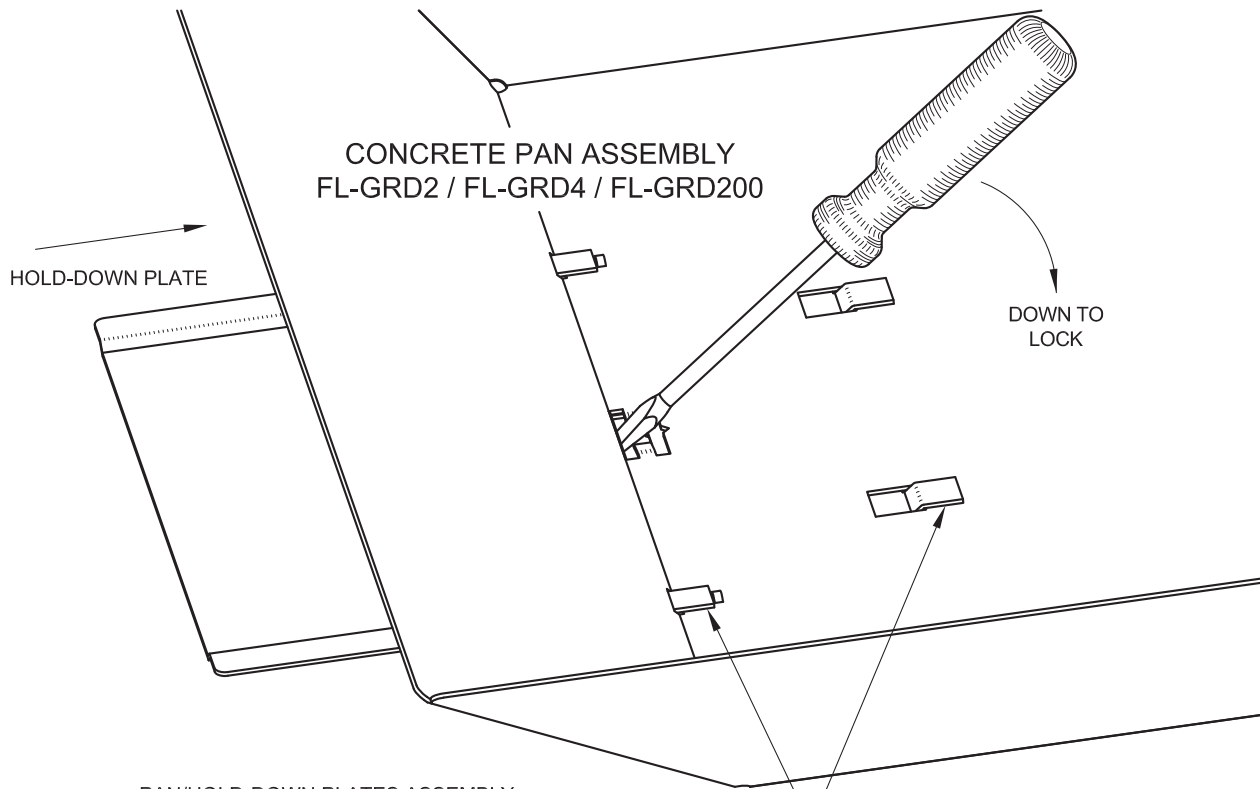
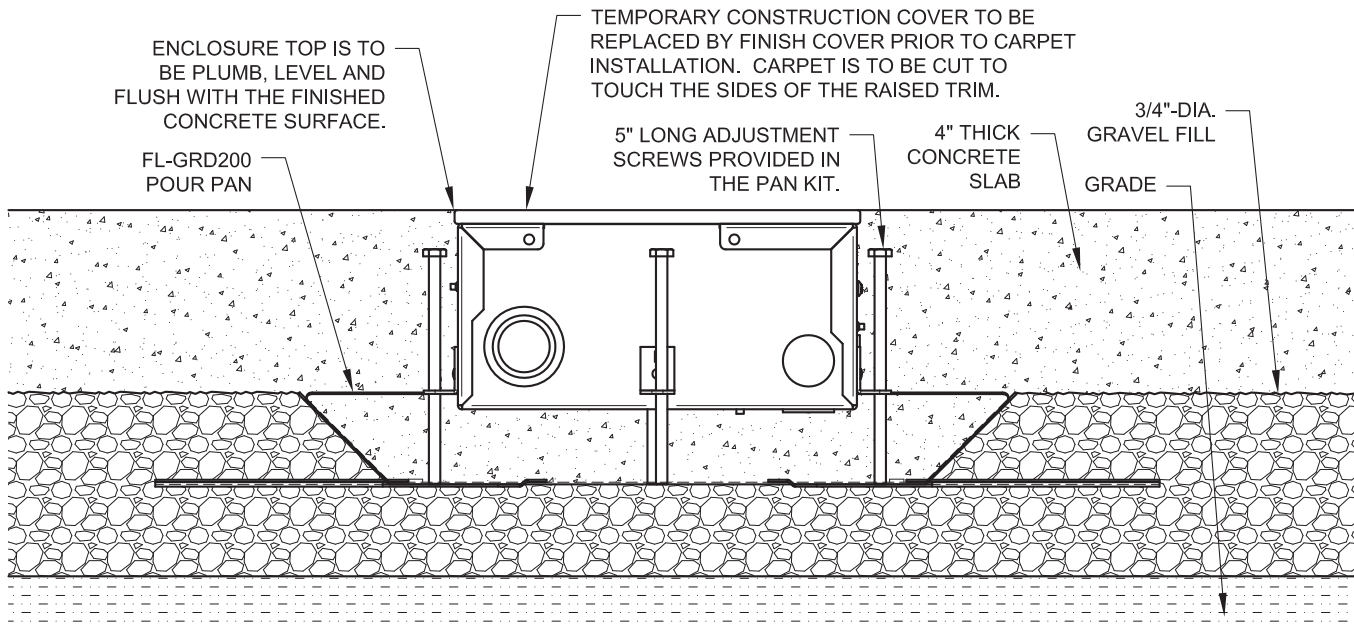

PAN/HOLD-DOWN PLATES ASSEMBLY:

INSERT THE TABS OF THE HOLD-DOWN PLATE INTO SLOTS IN THE PAN, AS SHOWN, AND PUSH THE PLATE INWARDS UNTIL IT STOPS.

INSERT THE TIP OF A FLAT-BLADED SCREWDRIVER INTO THE OPEN GAP AT THE INSIDE CORNER OF THE PAN. PUSH DOWN ON THE SCREWDRIVER HANDLE; THIS WILL BEND THE NARROW METAL STRIP ENOUGH TO CAPTURE AND LOCK THE HOLD-DOWN PLATE IN PLACE.

REPEAT THIS PROCEDURE WITH THE SECOND PLATE; THE PAN ASSEMBLY IS NOW READY FOR USE.