



Video Products Group

RN-410 SERIES AUDIO VIDEO SWITCHER

INSTALLATION AND OPERATING MANUAL



COMPLIANCE AND SAFETY

PROPRIETARY INFORMATION

All information in this manual is proprietary to and the property of FSR Inc. This publication is protected by the Federal Copyright Law, with all rights reserved. No part of this document may be reproduced, transcribed, or transmitted, in any form or by any means, without prior explicit written permission from FSR Inc.

OPERATOR'S SAFETY SUMMARY

The general safety information in this summary is for operating personnel.

Read Instructions. Read and understand all safety and operating instructions before using this equipment. Keep the instructions handy.

Removal of the top cover may expose dangerous voltages. To avoid personal injury, disconnect all power sources before removing the top cover. Do not operate the unit with the cover removed.

Power Source:

This product is intended to operate from the power source detailed in the specification section of this manual. Do not use any other power source or exceed voltage limits.

Grounding the Product:

This product is grounded through the grounding conductor of the power cord. To avoid electrical shock, plug the power cord into a properly wired receptacle before connecting to the product input or output terminals.

Use the Proper Power Cord Use only the power cord and connector specified for your product. Use only a power cord that is in good condition. Refer cord and connector changes to qualified service personnel.

TABLE OF CONTENTS

COMPLIANCE AND SAFETY	2
PROPRIETARY INFORMATION.....	2
OPERATOR'S SAFETY SUMMARY.....	2
INTRODUCTION	4
RN-410 FRONT PANEL OPERATION	4
SOURCE SELECTION.....	4
AUDIO LEVEL ADJUSTMENT.....	4
AUDIO TRIM ADJUSTMENTS.....	4
AUDIO CARD ABSENT.....	4
POWER UP / FAILURE OPERATION.....	5
DEFAULT FACTORY SETTINGS.....	5
TYPICAL APPLICATIONS	5
PINOUTS AND CABLING	6
SPECIFICATIONS	8
WARRANTY AND RETURN INFO	9
WARRANTY POLICY.....	9
SERVICE AND RETURN AUTHORIZATION.....	9
CONTACT INFORMATION.....	9

INTRODUCTION

This manual covers installation and operation the RN-410 family of audio video switchers. Most of the operating principals are identical on all models. The unique characteristics such as connectors and pinouts are detailed on the application drawings.

RN-410 FRONT PANEL OPERATION

SOURCE SELECTION

The source video and audio input are selected by pressing one of the 4 source buttons located on the left side of the front panel. A single lamp will be illuminated to indicate the selection. Note that the audio source input may be separately configured to a source different from that of the video input via the RS-232 interface. This is referred to as audio breakaway.

The audio breakaway feature, when configured, will result in the lamp of the current video source input selected being lit continuously and the audio breakaway source will blink intermittently at a rate of once per second. Pressing a source select button will return both audio and video to the selected source and terminate the audio breakaway feature.

AUDIO LEVEL ADJUSTMENT

The audio output level may be adjusted via the up and down buttons located on the right side of the front panel. The audio range may be adjusted in 1 dB increments from a floor of -45 dB to +5 dB by either pressing and holding the Vol Up or Down button or by discrete button presses. Each discrete press adjusts audio in 1dB steps. When continuously pressing a volume up or down button, the audio output level will be ramped in 1 dB increments, traversing the entire range from -45 to +5 dB in approximately 6 seconds. The 5 audio output lamps are illuminated accordingly to reflect 6 ranges (including all OFF).

Audio mute may be toggled on and off by pressing the Audio Mute button to the immediate left of the audio output level lamps. The user may adjust the audio output volume down while remaining in mute state. However, if the user presses the volume up button while muted then the audio will be unmuted and the audio output level will be adjusted accordingly.

AUDIO TRIM ADJUSTMENTS

The audio trim may also be adjusted for each of the 4 audio sources via the front panel. This is done by first pressing and holding the desired audio source input button (thus switching both video and audio to that source) and then simultaneously pressing the volume up or down buttons to adjust the trim for the selected source. Note that the lamps will not be illuminated to reflect the adjusted trim and will remain illuminated to reflect the audio output level as may have been adjusted as above. The audio trim may be ramped up or down by holding both the audio source button and the respective trim direction button and will traverse the -5 dB to +15 dB range in approximately 2-3 seconds. Or the user can adjust in discrete 1 dB increments by discrete volume up or down presses. When the audio source button is released, the audio trim adjustment is terminated.

AUDIO CARD ABSENT

The RN-410 is also available in configurations without an audio card. These RN-410 models have video capabilities only. However, the RN-410 chassis still contains the Volume lamps and buttons as well as the

Audio Mute lamp and button but they are effectively disabled and the lamps will not be lit. This provides a visual cue to user that the audio feature is absent on this model. The serial interface also provides indication of whether audio capability is present or not (see RN-410 Serial Protocol Manual).

POWER UP / FAILURE OPERATION

The RN-410 is capable of detecting imminent power failures and stores any configuration parameters to FLASH memory before complete power failure in order to restore the most recent operating configuration on start-up. A 5 second delay period upon power up allows for the power to stabilize. The user should wait 5 seconds after power up before operating or trying to send any serial commands to the unit.

DEFAULT FACTORY SETTINGS

The RN-410 can be returned to its default factory settings by first pressing and holding the Audio Mute button and then simultaneously pressing the Volume Up button. The default settings configure the default video and audio output to port one, the audio output level to -30 dB and the audio trim levels for each audio input to 0 dB.

TYPICAL APPLICATIONS

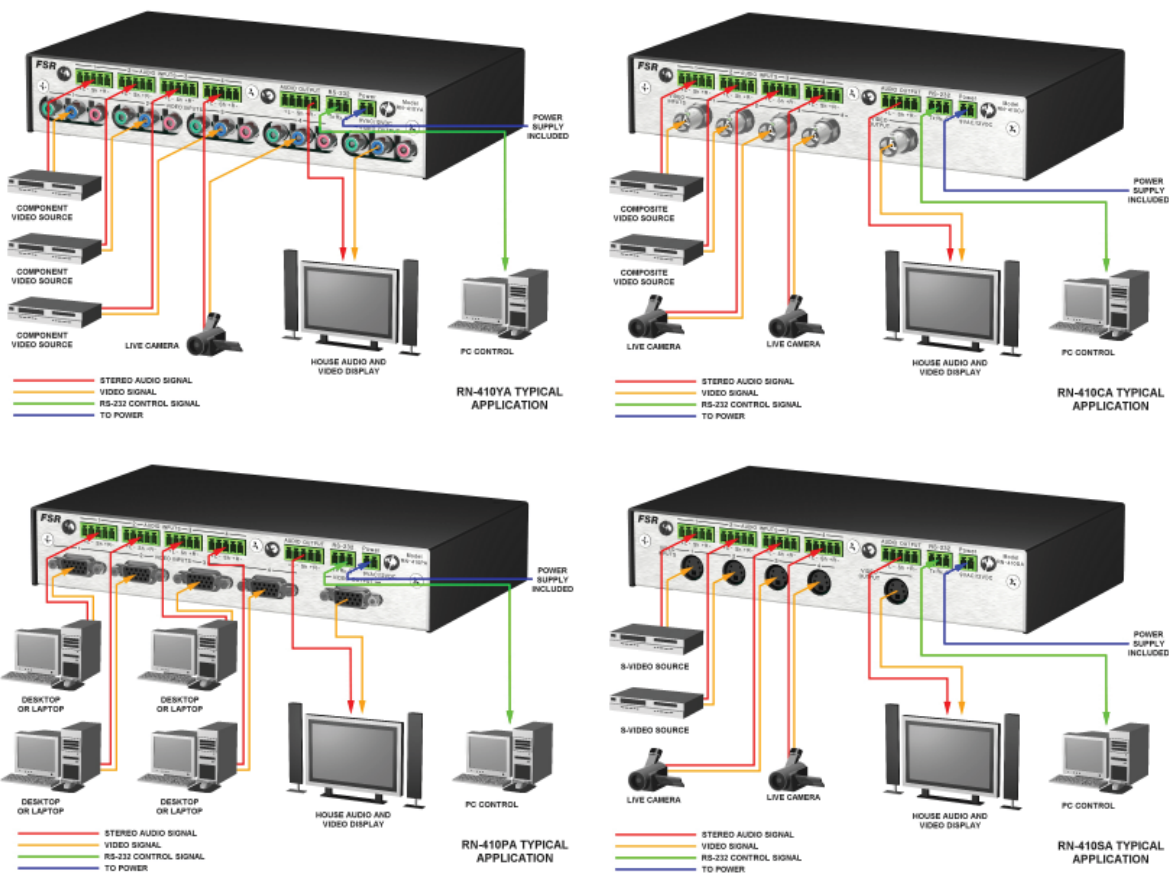

PINOOTS AND CABLING

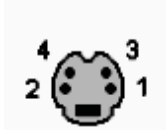

Cable Type: Standard 4 pin S-Video to two BNC male cable.

Maximum Recommended Length: 35 ft

Pin	Name	Description
1	GND	Ground (Y)
2	GND	Ground (C)
3	Y	Intensity (Luminance)
4	C	Color (Chrominance)

Pinout

Please see the RN-410 serial protocol manual included with the product for serial commands and other details on RS-232 control.

RS-232 HARDWARE CONFIGURATION	
BAUD RATE	38400
DATA BITS	8
STOP BITS	1
PARITY	NONE
FLOW CONTROL	NONE

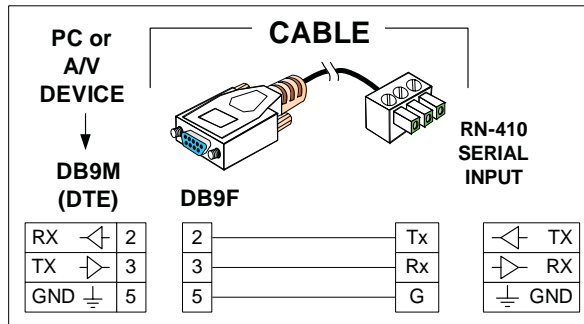

Serial Control Port for Control of DTE Devices

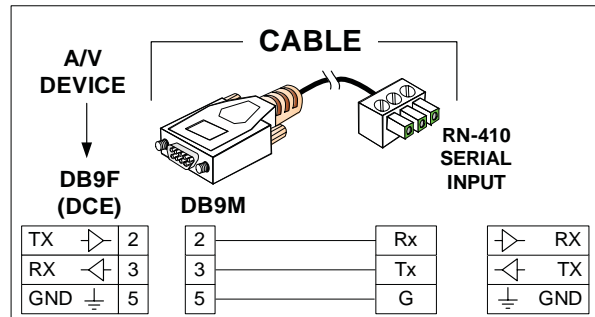

Serial Control Port for Control of DCE Devices

RN-410 AUDIO INPUT CONNECTOR WIRING

FROM A STEREO UNBALANCED SOURCE

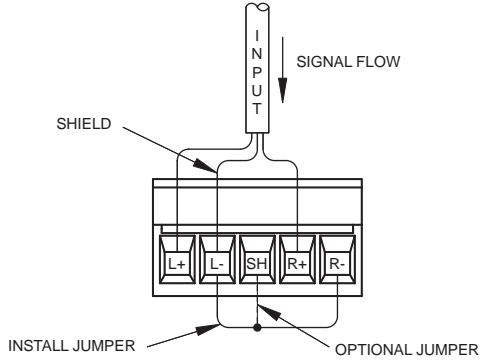

FROM A MONO UNBALANCED SOURCE

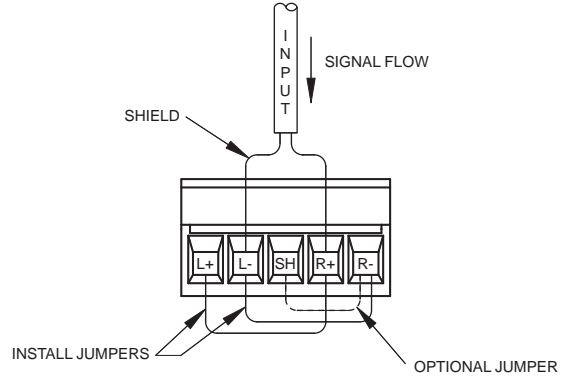

FROM A STEREO BALANCED SOURCE

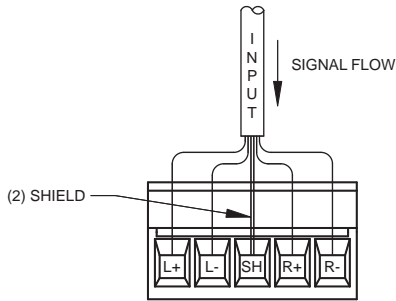

FROM A MONO BALANCED SOURCE

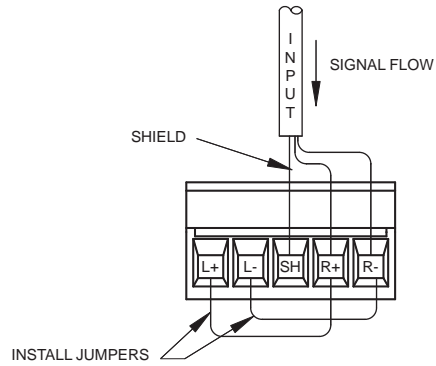

RN-410 AUDIO OUTPUT CONNECTOR WIRING

TO A STEREO UNBALANCED PREAMP INPUT

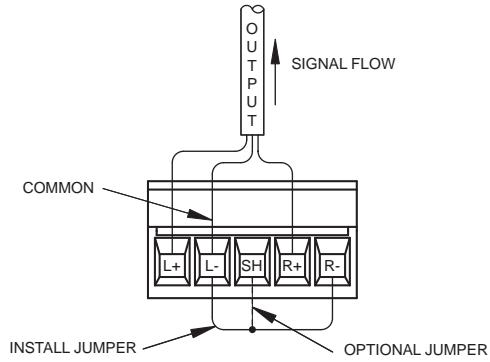

TO A MONO UNBALANCED PREAMP INPUT

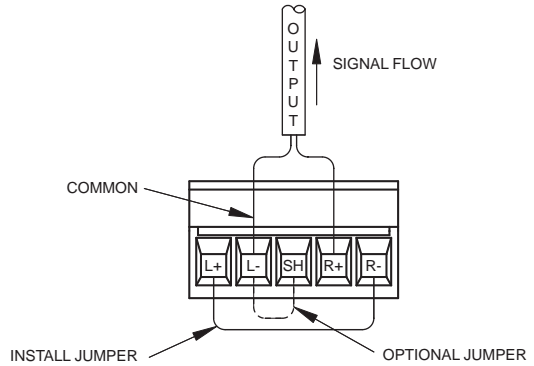

TO A STEREO BALANCED PREAMP INPUT

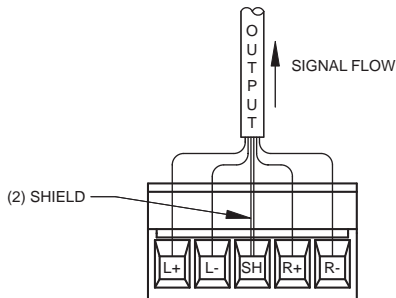

TO A MONO BALANCED PREAMP INPUT

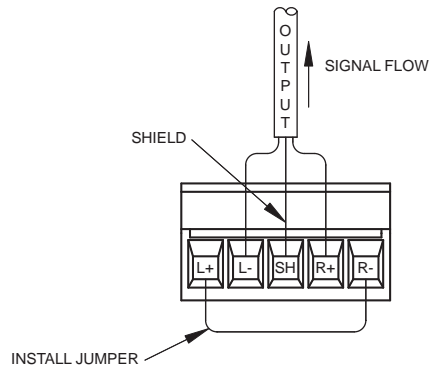

SPECIFICATIONS

VIDEO INPUT				
MODEL	RN-410YA	RN-410CA	RN-410P /PA	RN-410SA
SIGNAL TYPE	COMPONENT	COMPOSITE	RGB	S-VIDEO
CONNECTOR NUMBER/TYPE	4X3 RCA FEMALE	4 BNC FEMALE	4 HD-15 FEMALE	4-4 PIN FEMALE DIN
IMPEDANCE	75 OHM			
LEVEL	1 VOLT P/P			
VSWR	<1.1@250MHz	<1.3@100MHz	<1.1@250MHz	<1.3@100MHz
ISOLATION	>80dB@10MHz >65dB@100MHz	>80dB@10MHz >63dB@100MHz	>80dB@10MHz >65dB@100MHz	>80dB@10MHz >63dB@100MHz
DIFFERENTIAL PHASE	NA	0.05 degrees	NA	0.05 degrees
DIFFERENTIAL GAIN	NA	0.02%	NA	0.02%

VIDEO OUTPUT				
MODEL	RN-410YA	RN-410CA	RN-410P /PA	RN-410SA
SIGNAL TYPE	COMPONENT	COMPOSITE	RGB	S-VIDEO
CONNECTOR NUMBER/TYPE	1X3 RCA FEMALE	1 BNC FEMALE	1 HD-15 FEMALE	1-4 PIN FEMALE DIN
IMPEDANCE	75 OHM			
GAIN	UNITY INTO 75 OHMS			
OFFSET	15mV MAX	+/-4mV TYPICAL +/-15mV MAX	15mV MAX	+/-4mV TYPICAL +/-15mV MAX
BANDWIDTH	450 MHz	500 MHz	450MHz	500 MHz
FLATNESS	+/-0.25dB 0 to 150MHz +/-1dB 150 to 400 MHz	+/- .25dB to 100MHz	+/-0.25dB 0 TO 150MHz +/-1dB 150 TO 400 MHz	+/- .25dB to 100MHz

AUDIO	
BANDWIDTH	20 Hz to 20 kHz (+/- 0.1dB)
THD+NOISE	0.1% @20 kHz at rated max output
NOISE FLOOR	<-90dBu
CHANNEL SEPARATION	<-85dB @ 1kHz

AUDIO INPUTS	
SIGNAL TYPE	4 stereo balanced (may be used with unbalanced sources)
CONNECTOR NUMBER/TYPE	5 pin pluggable screw terminal
IMPEDANCE	20k ohms balanced
TRIM RANGE	-15dB to +5dB in 1dB steps
GAIN RANGE	-45dB to +5dB in 1dB steps

AUDIO OUTPUT	
NUMBER/TYPE	1 stereo balanced or unbalanced
CONNECTOR NUMBER/TYPE	One 5 pin pluggable screw terminal
IMPEDANCE	50 ohms
MAXIMUM LEVEL	600 ohms: +12dBm balanced / +6dBm unbalanced HI-Z: +14dBm balanced / +8dBm unbalanced

SYNC (RN-410P /PA only)	
INPUT IMPEDANCE	511 ohms
OUTPUT IMPEDANCE	75 ohms
INPUT LEVEL	TTL 2.0 V minimum
OUTPUT LEVEL	5 V into HI-Z / 2.4 V into 75 ohms
OUTPUT RISE AND FALL TIME	1nS
PROPAGATION DELAY	16nS

RS-232 HARDWARE CONFIGURATION	
BAUD RATE	38400
DATA BITS	8
STOP BITS	1
PARITY	NONE
FLOW CONTROL	NONE

POWER AND PHYSICAL	
POWER	9 VAC @500mA power supply included or 12VDC @ 300mA
CONNECTOR TYPE	2 pin pluggable screw terminals
MOUNTING	Standard 19" rack mount included
SHIPPING WEIGHT	3 lbs.

WARRANTY AND RETURN INFO

WARRANTY POLICY

This product is warranted against failures due to defective parts or faulty workmanship for a period of one year after delivery to the original owner. During this period, FSR will make any necessary repairs or replace the unit without charge for parts or labor. Shipping charges to the factory or repair station must be prepaid by the owner, return-shipping charges, via UPS / FedEx ground, will be paid by FSR.

This warranty applies only to the original owner and is not transferable. In addition, it does not apply to repairs done by other than the FSR factory or Authorized Repair Stations.

This warranty shall be cancelable by FSR at its sole discretion if the unit has been subjected to physical abuse or has been modified in any way without written authorization from FSR. FSR's liability under this warranty is limited to repair or replacement of the defective unit.

FSR will not be responsible for incidental or consequential damages resulting from the use or misuse of its products. Some states do not allow the exclusion of incidental or consequential damages, so the above limitations may not apply to you. This warranty gives you specific legal rights, and you may also have other rights which vary from state to state.

Warranty claims should be accompanied by a copy of the original purchase invoice showing the purchase date (if a Warranty Registration Card was mailed in at the time of purchase, this is not necessary). Before returning any equipment for repair, please read the important information on service below.

SERVICE AND RETURN AUTHORIZATION

Before returning any equipment for repair, please be sure that it is adequately packed and cushioned against damage in shipment, and that it is insured. We suggest that you save the original packaging and use it to ship the product for servicing. Also, please enclose a note giving your name, address, phone number and a description of the problem.

NOTE: All equipment being returned for repair must have a Return Authorization (RMA) Number. To get a RMA Number, please call FSR Service Department (973-785-4347).

Please display your RMA Number prominently on the front of all packages.

CONTACT INFORMATION

FSR Inc.
244 Bergen Boulevard,
West Paterson, NJ 07424

Tel: (973) 785-4347 · Fax: (973) 785-4207

E-Mail: sales@fsrinc.com · Web: <http://www.fsrinc.com>

