

1. 2-1/2 MAX TABLE THICKNESS. DETERMINE LOCATION AND CUT 7-1/4 x 8-3/16 HOLE WITH 3/8 MIN - 5/8 MAX RADIUS CORNERS IN TABLE TOP.

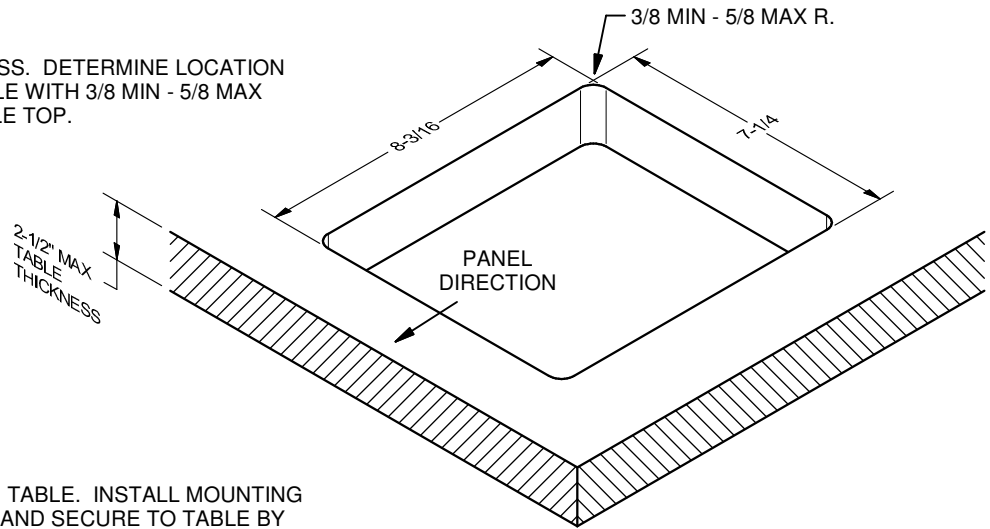

2. DROP TB-2G INTO HOLE IN TABLE. INSTALL MOUNTING BRACKETS TO ASSEMBLY AND SECURE TO TABLE BY TIGHTENING MOUNTING SCREWS TO UNDERSIDE OF TABLE.

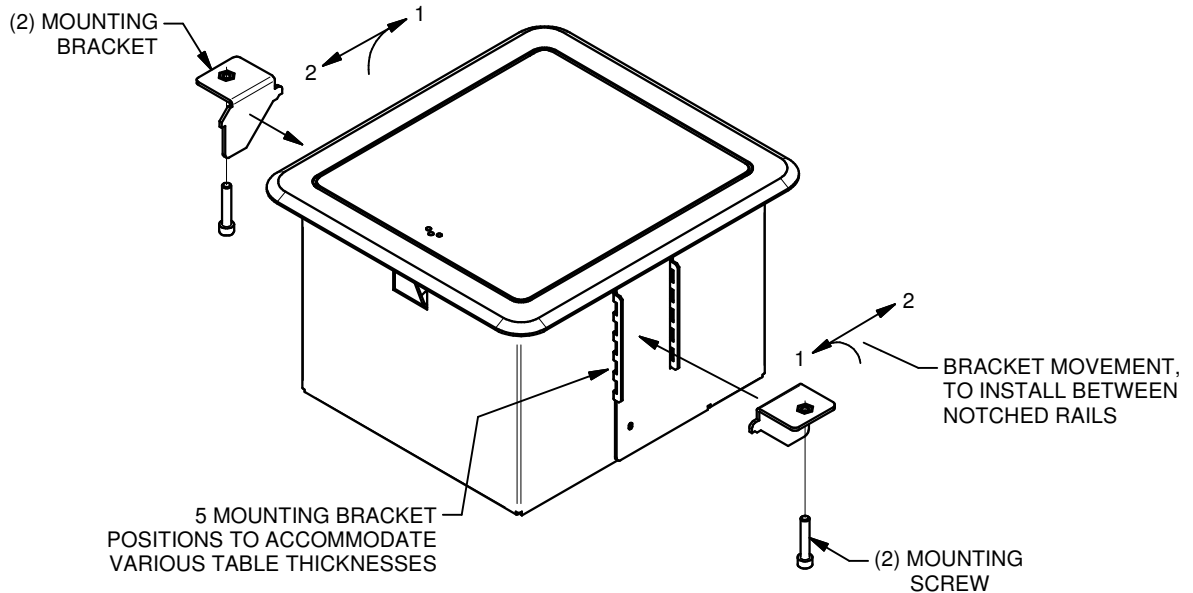
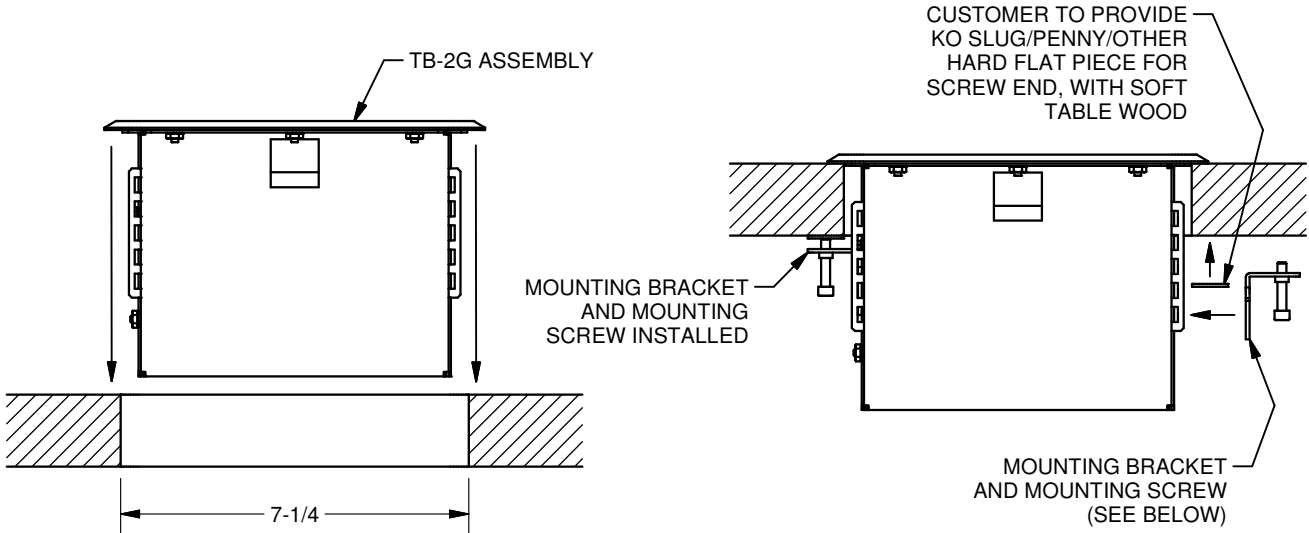

3. INSTALL ELECTRONIC COMPONENTS AND MAKE ELECTRICAL CONNECTIONS AS REQUIRED. BEFORE TIGHTENING CABLE-TIES, ENSURE THE ROUTING OF CABLES/WIRES DOES NOT INTERFERE WITH THE LATCH, OR CREATE ANY EXTRA LOAD ON THE GAS SPRING, OR LIMIT TRAVEL.

