

HOLE SIZE IN WALL		
MODEL	WIDTH	HEIGHT
WB-X1	9-1/2"	12-1/2"
WB-X2	12-1/2"	12-1/2"
WB-X3	12-1/2"	16-7/8"

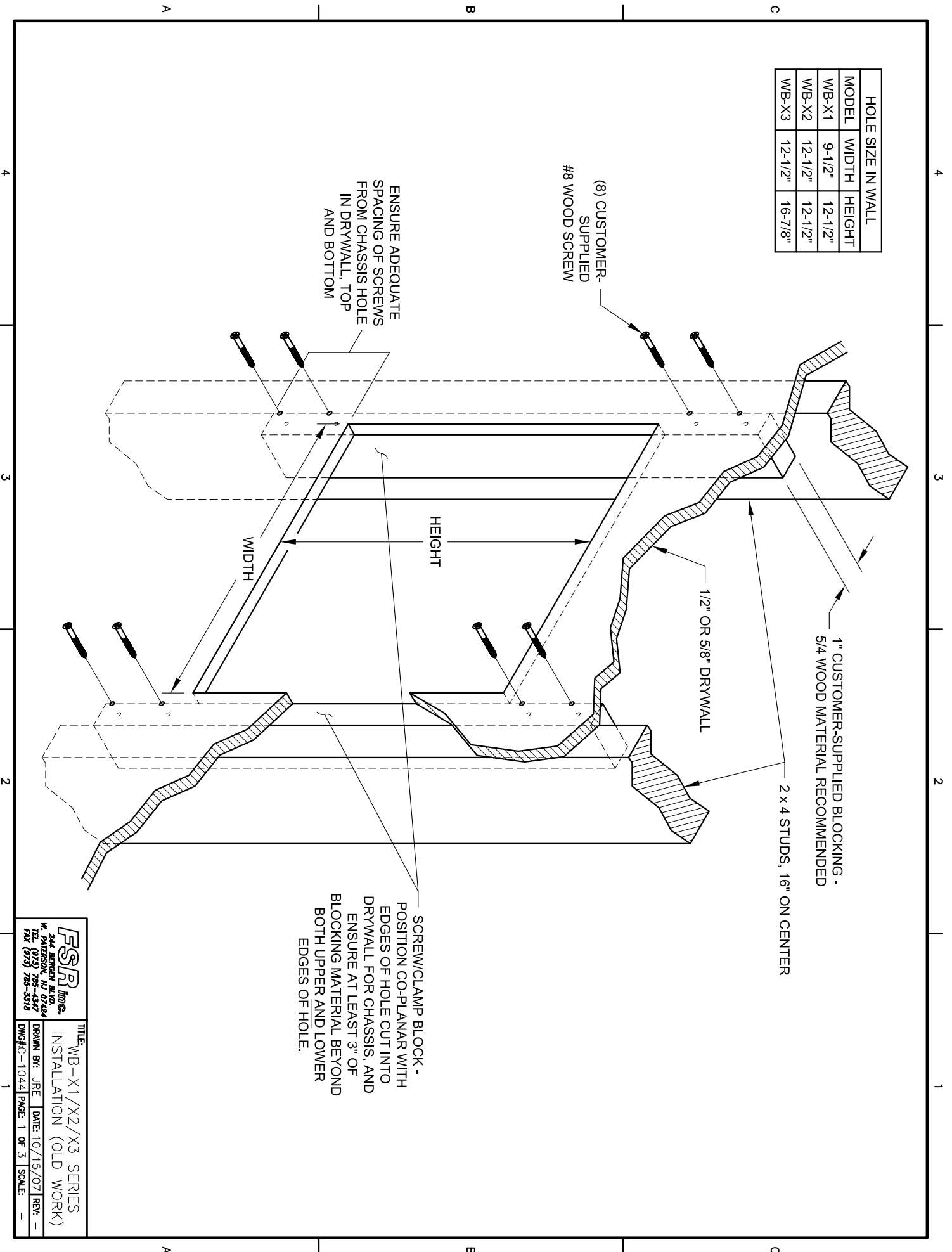

FSPR Inc.
 244 BERGEN BLVD.
 PATTERSON, NJ 07654
 TEL: (973) 788-3344
 FAX: (973) 788-3318

TITLE: WB-X1/X2/X3 SERIES
 INSTALLATION (OLD WORK)
 DRAWN BY: JRE DATE: 10/15/07 REV: -
 DWG#C-1044 PAGE: 1 OF 3 SCALE: -

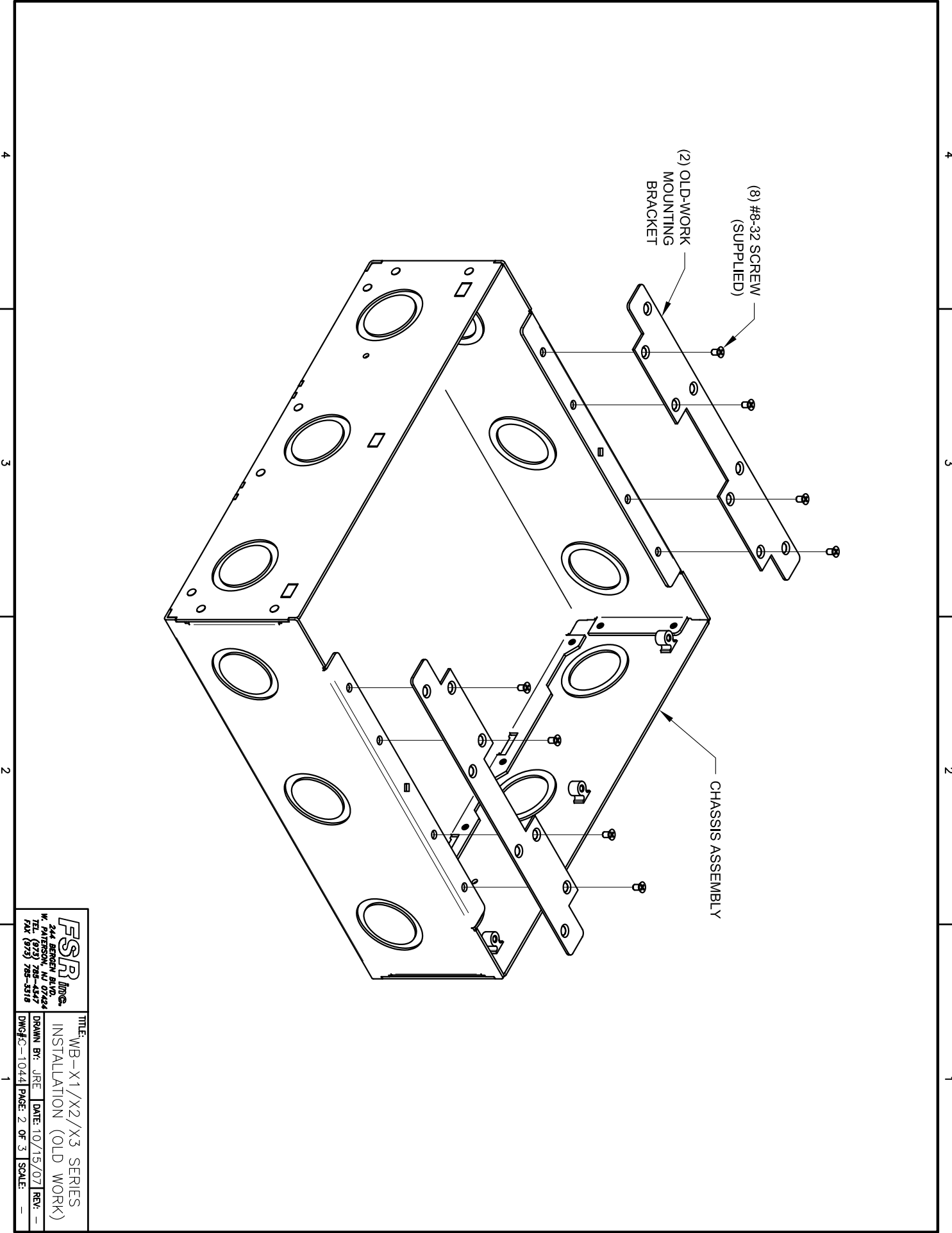

FSP Inc. 244 BERGEN BLVD. PATTERSON, NJ 07654 TEL: (973) 728-3318 FAX: (973) 728-3319	TITLE:	WB-X1/X2/X3 SERIES
	DRAWN BY:	JRE
DWG#:	1044	PAGE: 2 OF 3
DATE:	10/15/07	SCALE:
REV:	-	

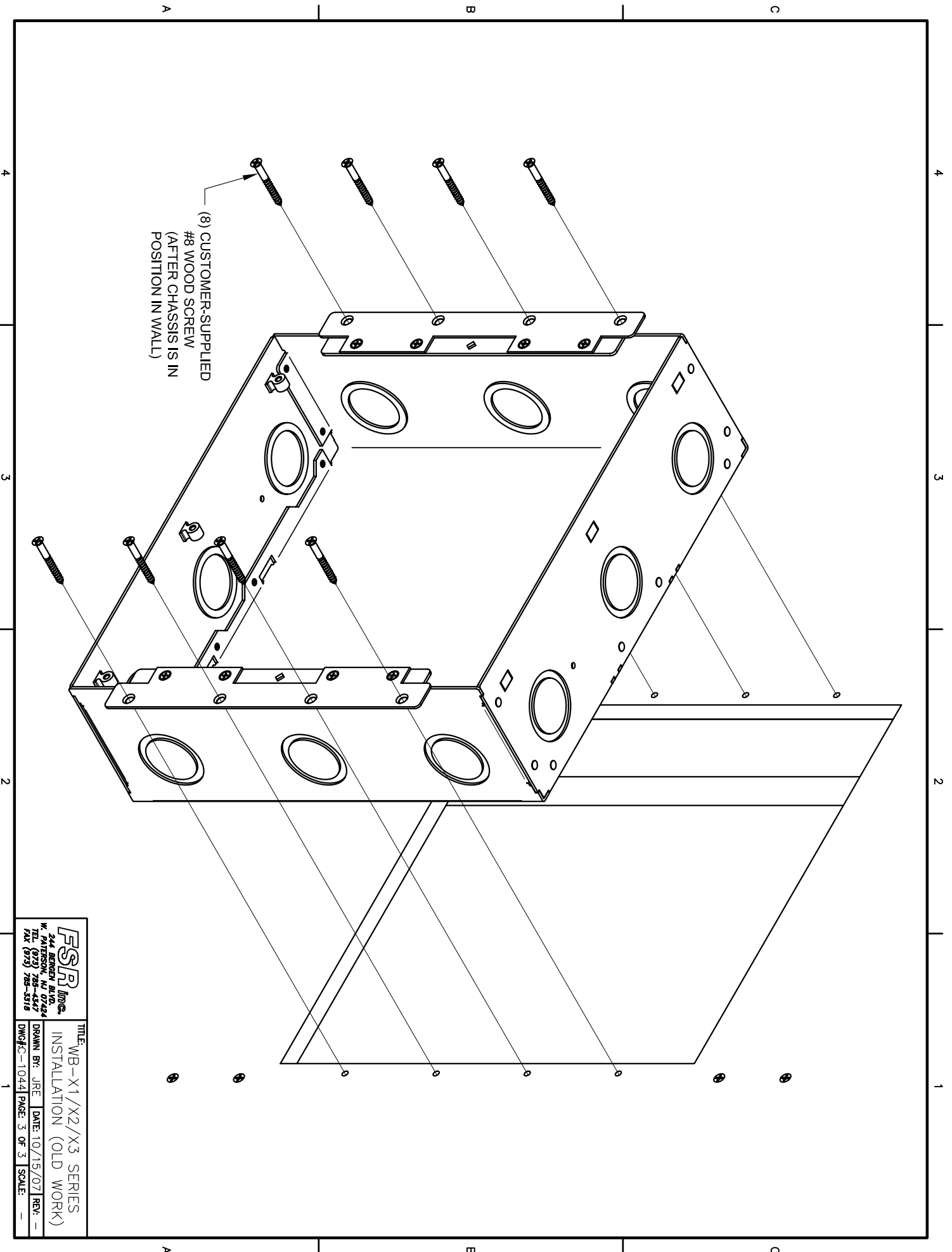

(8) CUSTOMER-SUPPLIED
#8 WOOD SCREW/
(AFTER CHASSIS IS IN
POSITION IN WALL)

FSP Inc. 244 BERGEN BLVD. PATTERSON, NJ 07654 TEL: (973) 728-3318 FAX: (973) 728-3319	TITLE:	WB-X1/X2/X3 SERIES
	DRAWN BY:	JRE
DWG#:	1044	PAGE: 3 OF 3
DATE:	10/15/07	SCALE:
REV:	-	